

P2 Datasheet	5
Functional description	6
OVERVIEW	6
FEATURES	6
DEVICE OS SUPPORT	6
Interfaces	7
BLOCK DIAGRAM	7
RF	7
APPROVED ANTENNAS	7
SWD/JTAG	8
3V3	9
Memory map	10
FLASH LAYOUT OVERVIEW	10
DCT LAYOUT	10
Pin and button definition	12
PIN MARKINGS	12
GPIO (DIGITAL I/O)	12
ADC (ANALOG TO DIGITAL CONVERTER)	13
UART SERIAL	13
SPI	14
I2C	14
PWM	15
PDM	15
USB	15
RGB LED	15
BOOT MODE PINS	16
BATTERY VOLTAGE	16
SETUP AND RESET BUTTON	16
5V TOLERANCE	16
BLE (BLUETOOTH LE)	17
SLEEP	17
RAM	17
RETAINED MEMORY	17
COMPLETE MODULE PIN LISTING	18
COMPLETE MODULE PIN DETAILS	20
1 GND	20
2 3V3_RF	20
3 3V3_RF	20
4 GND	20
5 3V3_IO	20
6 GND	21
7 NC	21
8 NC	21
9 NC	21
10 NC	21
11 NC	21

12 VBAT_MEAS	21
13 GND	22
14 NC	22
15 GND	22
16 NC	22
17 NC	22
18 NC	22
19 NC	22
20 NC	23
21 NC	23
22 NC	23
23 A5	23
24 NC	23
25 GND	23
26 3V3	24
27 3V3	24
28 GND	24
29 RGBR	24
30 D10	24
31 RGBB	24
32 RGBG	25
33 S6	25
34 RST	25
35 D1	25
36 D0	26
37 GND	26
38 NC	26
39 GND	26
40 S0	26
41 S1	27
42 S2	27
43 A1	27
44 S3	28
45 D2	28
46 MODE	28
47 S4	28
48 S5	29
49 A2	29
50 A0	29
51 D3	30
52 D4	30
53 D5	30
54 D7	30
55 D6	31
56 NC	31
57 NC	31
58 NC	31
59 GND	31
60 NC	31

61 USBDATA+	32
62 USBDATA-	32
63 RX	32
64 TX	32
65 GND	33
66 GND	33
67 GND	33
68 GND	33
69 GND	33
70 GND	33
71 GND	33
72 GND	34
73 GND	34
74 NC	34
75 NC	34
Technical specification	35
RECOMMENDED OPERATING CONDITIONS	35
I/O CHARACTERISTICS	35
POWER CONSUMPTION	35
Mechanical specifications	36
MODULE DIMENSIONS	36
RECOMMENDED PCB LAND PATTERN	36
3D MODELS	37
Reference design	38
Recommended solder reflow profile	39
Ordering information	40
Qualification and approvals	41
Product handling	42
MOISTURE SENSITIVITY LEVELS	42
ESD PRECAUTIONS	42
Assembly	43
WATER SOLUBLE FLUX	43
CONFORMAL COATINGS	43
Default settings	44
Intended applications	45
Glossary	46
FCC ISED CE warnings and end product labeling requirements	47
UNITED STATES (FCC)	47
CANADA (ISED)	49
EUROPEAN UNION (CE)	50
UNITED KINGDOM	50
OUTDOOR USE (WORLD)	50
Certification documents	51
BLUETOOTH - P2	51
CE (EUROPE) - P2	51

FCC (UNITED STATES) - P2	51
ISED (CANADA) - P2	51
ROHS - P2	51
UKCA (UNITED KINGDOM) - P2	51
Revision history	52
Known errata	54
Contact	55

P2 Datasheet



Functional description

OVERVIEW

The P2 is a SMD module with a microcontroller and Wi-Fi networking. The form-factor is the same as the P1, but the P2 supports 2.4 GHz and 5 GHz Wi-Fi, BLE, and has much larger RAM and flash that can support larger applications.

FEATURES

- 802.11a/b/g/n Wi-Fi, 2.4 GHz and 5 GHz
 - Integrated PCB antenna
 - Integrated U.FL connector for external antenna
 - Integrated RF switch
- BLE 5 using same antenna as Wi-Fi
- Realtek RTL8721DM MCU
 - ARM Cortex M33 CPU, 200 MHz
- 2048 KB (2 MB) user application maximum size
- 3072 KB (3 MB) of RAM available to user applications
- 2 MB flash file system
- FCC (United States), ISED (Canada), and CE (European Union) certified

DEVICE OS SUPPORT

The P2 requires Device OS 5.0.0 or later. It is recommended that you use the latest version in the 5.x release line.

Some P2 devices from the factory shipped with Device OS 3.2.1-p2.3. This version should not be used in production.

For information on upgrading Device OS, see [Version information](#). For the latest version shipped from the factory, see [Manufacturing firmware versions](#) page. See also [Long Term Support \(LTS\) releases](#).

Interfaces

BLOCK DIAGRAM

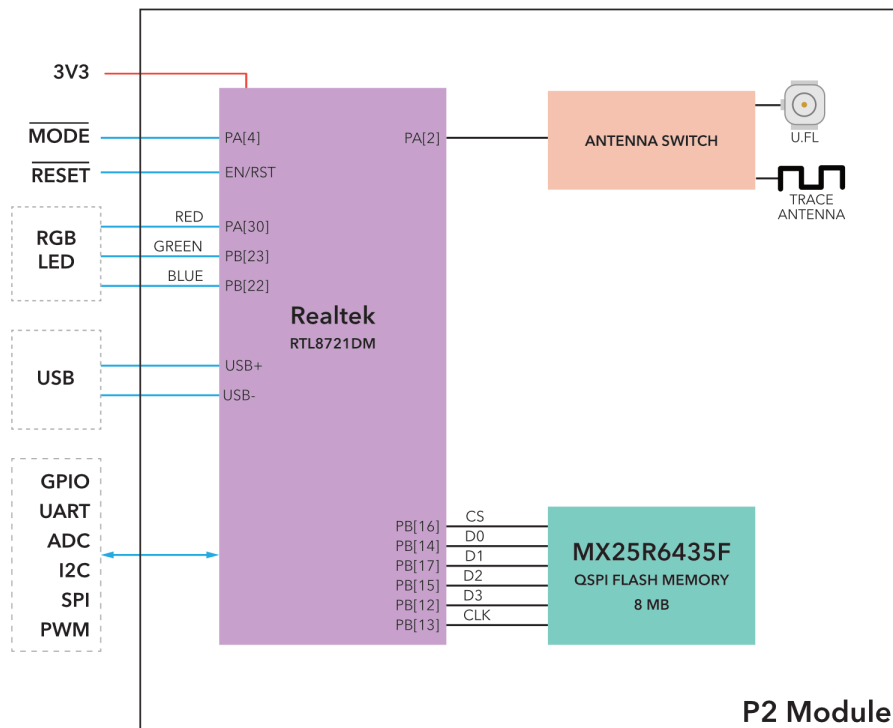

RF

- The P2 includes an on-module PCB trace antenna and a U.FL connector that allows the user to connect an external antenna.
- The antenna is selected in software. The default is the PCB trace antenna.
- The area surrounding the PCB antenna on the carrier PCB should be free of ground planes and signal traces for maximum Wi-Fi performance when using the trace antenna.
- Device operation in the 5150-5250 MHz band is only for indoor use to reduce the potential for harmful interference to co-channel mobile satellite systems.

APPROVED ANTENNAS

In addition to the built-in trace antenna, the following optional external antenna is certified for use with the P2:

Antenna	SKU
Particle P2/Photon2 Wi-Fi Antenna 2.4/5GHz, [x1]	PARANTWM1EA
Particle P2/Photon2 Wi-Fi Antenna 2.4/5GHz, [x50]	PARANTWMITY

This antenna is used for both Wi-Fi and BLE. In order to use an external antenna, it must be selected in software.

A different dual-band antenna can be used but this will likely require both intentional and unintentional radiator certification.

SWD/JTAG

The P2 module supports programming and debugging use SWD (Serial Wire Debug) on pins D6 and D7.

Pin	JTAG	MCU Pin	P2 Pin #	Pull at boot
D7	SWDIO	PA[27]	54	Pull-up
D6	SWCLK	PB[3]	55	Pull-down
3V3	Power			
GND	Ground			
RST	Reset			

When the bootloader starts, for a brief period of time a weak pull-up is applied to pin D7 and pull-down to pin D6 to detect whether a SWD debugger is attached. After boot, you can use these pins for regular GPIO, but beware of a possible GPIO state change caused by the pull-up or pull-down when using these pins as output.

Note that SWD is shared with GPIO pins D6 and D7, and by default SWD is only enabled while the bootloader is running, immediately at boot, and when in DFU mode (blinking yellow). Only Debug builds in Particle Workbench have SWD enabled in when user firmware is running.

3V3 is used to supply power to RTL8721 MCU, Wi-Fi, memory, etc.. 3.3V at a minimum of 500 mA is required.

These limits do not include any 3.3V peripherals on your base board, so that may increase the current requirements.

Power supply requirements:

- 3.3V output
- Maximum 5% voltage drop
- 100 mV peak-to-peak ripple maximum
- 500 mA minimum output current at 3.3V recommended for future compatibility
- Maintain these values at no-load as well as maximum load

In some cases, it may be necessary to add a supervisory/reset IC, such as the [SG Micro SGM809-RXN3L/TR](#).

- If your power supply has a slew rate from 1.5V to 3.0V slower than 15 ms, a reset IC is required.
- If your power supply at power off cannot be guaranteed to drop below 0.3V before powering back up, a reset IC required.

Memory map

FLASH LAYOUT OVERVIEW

Address	File	Purpose
0x00000000	p2-prebootloader-mbr	This file is factory configured and must never be overwritten
0x00004000	p2-bootloader	Device OS bootloader
0x00014000	p2-prebootloader-part1	Bootloader for KM0 processor, infrequently modified
0x00060000	p2-system-part1	Device OS system part

- The location of the user binary is dependent on the size of the user binary and is not flashed to a fixed location.
- **Do not chip erase the RTL872x under any circumstances!** Also do not flash anything to address 0 (prebootloader-mbr). The prebootloader-mbr is factory configured for your specific device with the private keys necessary for secure boot. If you erase or overwrite this portion of the flash you will not be able to program or use the device again.

DCT LAYOUT

The DCT area of flash memory has been mapped to a separate DFU media device so that we can incrementally update the application data. This allows one item (say, server public key) to be updated without erasing the other items.

Region	Offset	Size
system flags	0	32
version	32	2
device private key	34	1216
device public key	1250	384
ip config	1634	120
feature flags	1754	4
country code	1758	4
claim code	1762	63
claimed	1825	1
ssid prefix	1826	26
device code	1852	6
version string	1858	32
dns resolve	1890	128
reserved1	2018	64
server public key	2082	768
padding	2850	2
flash modules	2852	100
product store	2952	24
antenna selection	2976	1
cloud transport	2977	1
alt device public key	2978	128
alt device private key	3106	192
alt server public key	3298	192

alt server address	3490	128
device id	3618	12
radio flags	3630	1
mode button mirror	3631	32
led mirror	3663	96
led theme	3759	64
reserved2	3823	435

Note: Writing 0xFF to offset 34 (DEFAULT) or 3106 (ALTERNATE) will cause the device to regenerate a new private key on the next boot. Alternate keys are currently unsupported on the P1 but are used on the Electron as UDP/ECC keys. You should not need to use this feature unless your keys are corrupted.

```
// Regenerate Default Keys
echo -en "\xFF" > fillbyte && dfu-util -d 2b04:d00a -a 1 -s 34 -D fillbyte
// Regenerate Alternate Keys
echo -en "\xFF" > fillbyte && dfu-util -d 2b04:d00a -a 1 -s 3106 -D
fillbyte
```

Pin and button definition

Peripheral Type	Qty	Input(I) / Output(O)
Digital	22	I/O
Analog (ADC)	6	I
SPI	2	I/O
I2C	1	I/O
UART	3	I/O
USB	1	I/O
PWM	5	O

PIN MARKINGS

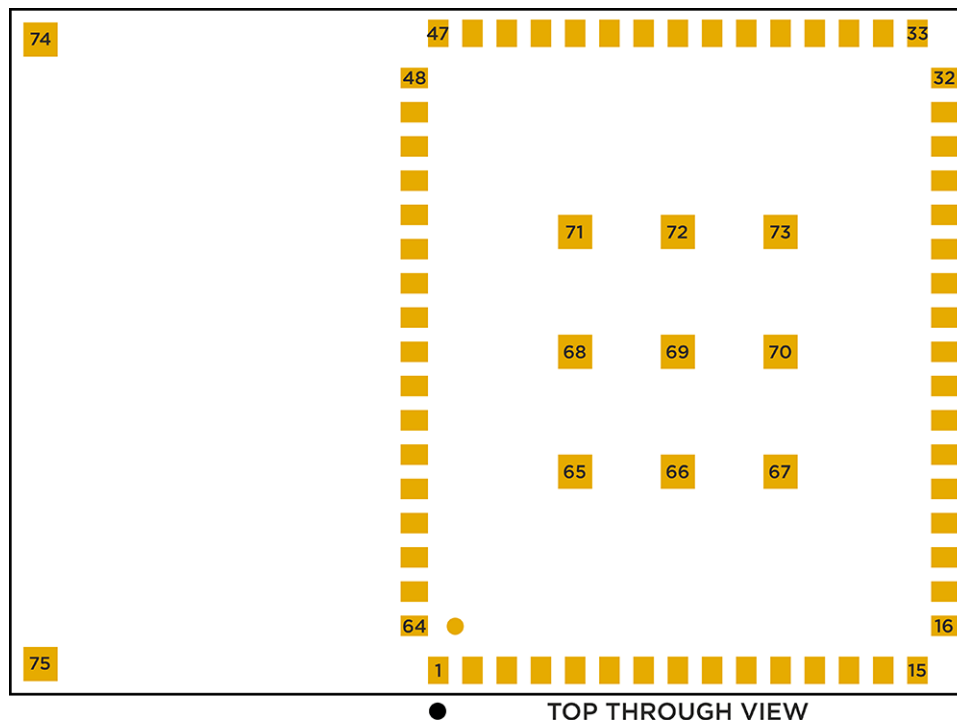

GPIO (DIGITAL I/O)

Pin	P2 Pin Name	P2 GPIO	MCU	Special boot function
23	A5 / D14	✓	PB[4]	
30	D10 / WKP	✓	PA[15]	
33	S6 / D21	✓	PB[31]	
35	D1 / A4	✓	PB[5]	
36	D0 / A3	✓	PB[6]	
40	S0 / D15	✓	PA[12]	
41	S1 / D16	✓	PA[13]	
42	S2 / D17	✓	PA[14]	
43	A1 / D12	✓	PB[2]	
44	S3 / D18	✓	PB[26]	
45	D2	✓	PA[16]	
47	S4 / D19	✓	PA[0]	
49	A2 / D13	✓	PB[7]	
50	A0 / D11	✓	PB[1]	

51	D3	✓	PA[17]	
52	D4	✓	PA[18]	
53	D5	✓	PA[19]	
54	D7	✓	PA[27]	SWDIO. 40K pull-up at boot. Low at boot triggers MCU test mode.
55	D6	✓	PB[3]	SWCLK. 40K pull-down at boot.
63	RX / D9	✓	PA[8]	
64	TX / D8	✓	PA[7]	Low at boot triggers ISP flash download

- The drive strength is 4 mA per pin in normal drive and 12 mA per pin in high drive mode on the P2.
- There is a maximum of 200 mA across all pins. The total maximum could be further limited by your 3.3V regulator.
- Drive strength selection using [pinSetDriveStrength](#) is only available in Device OS 5.5.0 and later on the P2.
- On the P2, Pin RGBR (PA[30]) has a 10K hardware pull-up in the module because it's a trap pin that controls the behavior of the internal 1.1V regulator. This does not affect the RGB LED but could affect your design if you are repurposing this pin as GPIO. You must not hold this pin low at boot.
- Pins TX, D6, and D7 have additional limitations, see [boot mode pins](#), below.

ADC (ANALOG TO DIGITAL CONVERTER)

The P2 supports six ADC inputs.

Pin	Pin Name	Description	Interface	MCU
23	A5 / D14	A5 Analog in, GPIO, PWM.	ADC_0	PB[4]
35	D1 / A4	D1 GPIO, PWM, I2C SCL, A4 Analog In	ADC_1	PB[5]
36	D0 / A3	D0 GPIO, I2C SDA, A3 Analog In	ADC_2	PB[6]
43	A1 / D12	A1 Analog in, PDM DAT, GPIO	ADC_5	PB[2]
49	A2 / D13	A2 Analog in, PWM, GPIO	ADC_3	PB[7]
50	A0 / D11	A0 Analog in, PDM CLK, GPIO	ADC_4	PB[1]

- ADC inputs are single-ended and limited to 0 to 3.3V
- Resolution is 12 bits

The `VBAT_MEAS` pin is connected to Li+ on the Photon 2 and is used to measure the battery voltage by using `analogRead(A6)`. The value returned is 0 - 4095 (inclusive, 12-bit) but represents voltage from 0 - 5 VDC, not 3.3V as is the case with the other ADC inputs.

UART SERIAL

The P2 supports three UART serial interfaces.

Pin	Pin Name	Description	Interface	MCU
30	D10 / WKP	D10 GPIO, Serial 3 CTS, WKP. (Was WKP/A7 on P1.)	Serial3 (CTS)	PA[15]
40	S0 / D15	S0 GPIO, PWM, SPI MOSI, Serial3 TX, I2S MCLK. (Was P1S0 on P1.)	Serial3 (TX)	PA[12]
41	S1 / D16	S1 GPIO, PWM, SPI MISO, Serial3 RX. (Was P1S1 on P1.)	Serial3 (RX)	PA[13]
42	S2 / D17	S2 GPIO, SPI SCK, Serial3 RTS. (Was P1S2 on P1.)	Serial3 (RTS)	PA[14]
45	D2	D2 GPIO, Serial2 RTS, SPI1 MOSI	Serial2 (RTS)	PA[16]
51	D3	D3 GPIO, Serial2 CTS, SPI1 MISO	Serial2 (CTS)	PA[17]

52	D4	D4 GPIO, Serial2 TX, SPI1 SCK	Serial2 (TX)	PA[18]
53	D5	D5 GPIO, Serial2 RX, SPI1 SS	Serial2 (RX)	PA[19]
63	RX / D9	Serial1 RX (received data), GPIO	Serial1 (RX)	PA[8]
64	TX / D8	Serial1 TX (transmitted data), GPIO	Serial1 (TX)	PA[7]

- The UART pins are 3.3V and must not be connected directly to a RS-232C port or to a 5V TTL serial port
- Hardware flow control is optional; if not used then the RTS and CTS pins can be used as regular GPIO
- Serial1 uses the RTL872x UART_LOG peripheral
- Serial2 uses the RTL872x HS_UART0 peripheral
- Serial3 uses the RTL872x LP_UART peripheral
- Supported baud rates: 110, 300, 600, 1200, 2400, 4800, 9600, 14400, 19200, 28800, 38400, 57600, 76800, 115200, 128000, 153600, 230400, 380400, 460800, 500000, 921600, 1000000, 1382400, 1444400, 1500000, 1843200, 2000000, 2100000, 2764800, 3000000, 3250000, 3692300, 3750000, 4000000, 6000000

SPI

The P2 supports two SPI (serial peripheral interconnect) ports.

Pin	Pin Name	Description	Interface	MCU
40	S0 / D15	S0 GPIO, PWM, SPI MOSI, Serial3 TX, I2S MCLK. (Was P1S0 on P1.)	SPI (MOSI)	PA[12]
41	S1 / D16	S1 GPIO, PWM, SPI MISO, Serial3 RX. (Was P1S1 on P1.)	SPI (MISO)	PA[13]
42	S2 / D17	S2 GPIO, SPI SCK, Serial3 RTS. (Was P1S2 on P1.)	SPI (SCK)	PA[14]
44	S3 / D18	S3 GPIO, I2S TX. (Was P1S3 on P1.), SPI SS	SPI (SS)	PB[26]
45	D2	D2 GPIO, Serial2 RTS, SPI1 MOSI	SPI1 (MOSI)	PA[16]
51	D3	D3 GPIO, Serial2 CTS, SPI1 MISO	SPI1 (MISO)	PA[17]
52	D4	D4 GPIO, Serial2 TX, SPI1 SCK	SPI1 (SCK)	PA[18]
53	D5	D5 GPIO, Serial2 RX, SPI1 SS	SPI1 (SS)	PA[19]

- The SPI port is 3.3V and must not be connected directly to devices that drive MISO at 5V
- If not using a SPI port, its pins can be used as GPIO
- Any pins can be used as the SPI chip select
- Multiple devices can generally share a single SPI port
- SPI uses the RTL872x SPI1 peripheral (25 MHz maximum speed)
- SPI1 uses the RTL872x SPI0 peripheral (50 MHz maximum speed)

If you are using SPI, Device OS 5.3.1 or later is recommended. Prior to that version, SPI ran at half of the set speed, and SPI1 ran at double the set speed. Timing has also been improved for large DMA transfers; prior to 5.3.1, there could be 1 μ s gaps for every 16 bytes of data transferred.

I2C

The P2 supports one I2C (two-wire serial interface) port.

Pin	Pin Name	Description	Interface	MCU
35	D1 / A4	D1 GPIO, PWM, I2C SCL, A4 Analog In	Wire (SCL)	PB[5]
36	D0 / A3	D0 GPIO, I2C SDA, A3 Analog In	Wire (SDA)	PB[6]

- The I2C port is 3.3V and must not be connected directly a 5V I2C bus

- Maximum bus speed is 400 kHz
- External pull-up resistors are required for I2C
- If not using I2C, pins D0 and D1 can be used as GPIO or analog input.

PWM

The P2 supports PWM (pulse-width modulation) on the following pins:

Pin	Pin Name	Description	MCU
23	A5 / D14	A5 Analog in, GPIO, PWM.	PB[4]
35	D1 / A4	D1 GPIO, PWM, I2C SCL, A4 Analog In	PB[5]
40	S0 / D15	S0 GPIO, PWM, SPI MOSI, Serial3 TX, I2S MCLK. (Was P1S0 on P1.)	PA[12]
41	S1 / D16	S1 GPIO, PWM, SPI MISO, Serial3 RX. (Was P1S1 on P1.)	PA[13]
49	A2 / D13	A2 Analog in, PWM, GPIO	PB[7]

All available PWM pins on the P2 share a single timer. This means that they must all share a single frequency, but can have different duty cycles.

PDM

Pulse density modulation digital microphones can be used with the [Microphone_PDM](#) library and the P2, but only on specific pins:

Pin	Pin Name	Description	MCU
43	A1 / D12	A1 Analog in, PDM DAT, GPIO	PB[2]
50	A0 / D11	A0 Analog in, PDM CLK, GPIO	PB[1]

USB

The P2 supports a USB interface for programming the device and for USB serial (CDC) communications. The module itself does not contain a USB connector; you typically add a micro USB or USB C connector on your base board. It is optional but recommended.

Pin	Pin Name	Description	MCU
61	USBDATA+	USB Data+	PA[26]
62	USBDATA-	USB Data-	PA[25]

RGB LED

The P2 supports an external common anode RGB LED.

One common LED that meets the requirements is the [Cree CLMVC-FKA-CL1D1L71BB7C3C3](#) which is inexpensive and easily procured. You need to add three current limiting resistors. With this LED, we typically use 1K ohm current limiting resistors. These are much larger than necessary. They make the LED less blinding but still provide sufficient current to light the LEDs. If you want maximum brightness you should use the calculated values - 33 ohm on red, and 66 ohm on green and blue.

A detailed explanation of different color codes of the RGB system LED can be found [here](#).

The use of the RGB LED is optional, however it is highly recommended as troubleshooting the device without the LED is very difficult.

Pin	Pin Name	Description	MCU
29	RGBR	RGB LED Red. Has 10K hardware pull-up. Do not hold low at boot.	PA[30]
31	RGBB	RGB LED Blue	PB[22]
32	RGBG	RGB LED Green	PB[23]

- On the P2, Pin RGBR (PA[30]) has a 10K hardware pull-up in the module because it's a trap pin that controls the behavior of the internal 1.1V regulator. This does not affect the RGB LED but could affect your design if you are repurposing this pin as GPIO. You must not hold this pin low at boot.

BOOT MODE PINS

These pins have a special function at boot. Beware when using these pins as input as they can trigger special modes in the MCU.

Pin	Pin Name	Description	MCU
54	D7	SWDIO. 40K pull-up at boot. Low at boot triggers MCU test mode.	PA[27]
55	D6	SWCLK. 40K pull-down at boot.	PB[3]
64	TX / D8	Low at boot triggers ISP flash download	PA[7]

BATTERY VOLTAGE

The P2 does not include a LiPo battery connector, but if you connect your battery to `VBAT_MEAS`, this technique can be used to measure the battery voltage:

```
float voltage = analogRead(A6) /
819.2;
```

The constant is from the ADC range (0 - 4095) mapped to the voltage from 0 - 5 VDC (the maximum supported on `VBAT_MEAS`).

SETUP AND RESET BUTTON

It is highly recommended that you add MODE (SETUP) and RESET buttons to your base board using momentary switches that connect to GND. These are necessary to change the operating mode of the device, for example to enter listening or DFU mode.

Pin	Pin Name	Description	MCU
34	RST	Hardware reset. Pull low to reset; can leave unconnected in normal operation.	CHIP_EN
46	MODE	MODE button. Pin number constant is BTN. External pull-up required!	PA[4]

The MODE button does not have a hardware pull-up on it, so you must add an external pull-up (2.2K to 10K) to 3V3, or connect it to 3V3 if not using a button.

The RST pin does have an internal weak pull-up, but you may want to add external pull-up on that as well, especially if you use an off-board reset button connected by long wires.

5V TOLERANCE

GPIO and all ports such as I2C, SPI, UART serial, etc. are **not** 5V tolerant. The only pins that are 5V tolerant are:

Pin	Pin Name	Description	MCU
12	VBAT_MEAS	Battery voltage measurement (optional).	
61	USBDATA+	USB Data+	PA[26]
62	USBDATA-	USB Data-	PA[25]

BLE (BLUETOOTH LE)

BLE Central Mode on the P2 and Photon 2 is only supported in Device OS 5.1.0 and later. Earlier versions only supported BLE Peripheral Mode.

SLEEP

The P2 can wake from `STOP` or `ULTRA_LOW_POWER` sleep mode on any GPIO, `RISING`, `FALLING`, or `CHANGE`.

The P2 can only wake from `HIBERNATE` sleep mode on pin D10, `RISING`, `FALLING`, or `CHANGE`. Pin D10 is the same module pin location (pin 30) as the P1 WKP (A7) pin.

The P2 preserves the state of outputs during `STOP` or `ULTRA_LOW_POWER` sleep mode. In `HIBERNATE`, outputs are high-impedance.

Most pins can use `INPUT_PULLUP` or `INPUT_PULLDOWN` in sleep modes. The exceptions in `HIBERNATE` sleep mode where pins S4, S5, and S6 can only use an external hardware pull-up or pull down.

Pin	Pin Name	Description	Interface	MCU
30	D10 / WKP	D10 GPIO, Serial 3 CTS, WKP. (Was WKP/A7 on P1.)	Only this pin can wake from <code>HIBERNATE</code> sleep mode.	PA[15]
33	S6 / D21	S6 GPIO, I2S WS. (Was P1S6/TESTMODE on P1.)	No internal pull up or pull down in <code>HIBERNATE</code> sleep mode.	PB[31]
47	S4 / D19	S4 GPIO, I2S RX. (Was P1S4 on P1.)	No internal pull up or pull down in <code>HIBERNATE</code> sleep mode.	PA[0]
48	S5 / D20	S5 GPIO, I2S CLK. (Was P1S5 on P1.)	No internal pull up or pull down in <code>HIBERNATE</code> sleep mode.	PB[29]

RAM

The P2 has 512 KB of static RAM (SRAM) and 4 MB of pseudo-static RAM (PSRAM).

Around 3072 KB (3 MB) of RAM is available for user applications. Heap allocations are made first from SRAM, then from PSRAM, as necessary.

RETAINED MEMORY

The P2 and Photon 2 have limited support for retained memory in Device OS 5.3.1 and later:

Retained memory is preserved on RTL872x devices in the following cases:

Case	Saved
When entering sleep modes	5.3.1 and later
OTA firmware updates	5.3.1 and later
<code>System.backupRamSync()</code>	5.3.1 and later

<code>System.reset()</code>	Not saved
Reset button or reset pin	Not saved
Every 10 seconds	5.3.1 to 5.8.0 only

Calling `System.backupRamSync()` will manually save the contents of retained memory to a dedicated flash page on the RTL872x processor and will be restored after the device is reset. You should avoid saving the data extremely frequently as it is slower than RAM and will cause flash wear and is relatively slow to execute.

Prior to Device OS 5.3.1, retained memory is not supported on RTL872x devices. The flash file system can be used, or you can use an external chip such as an I2C or SPI FRAM.

Retained memory is 3068 bytes.

COMPLETE MODULE PIN LISTING

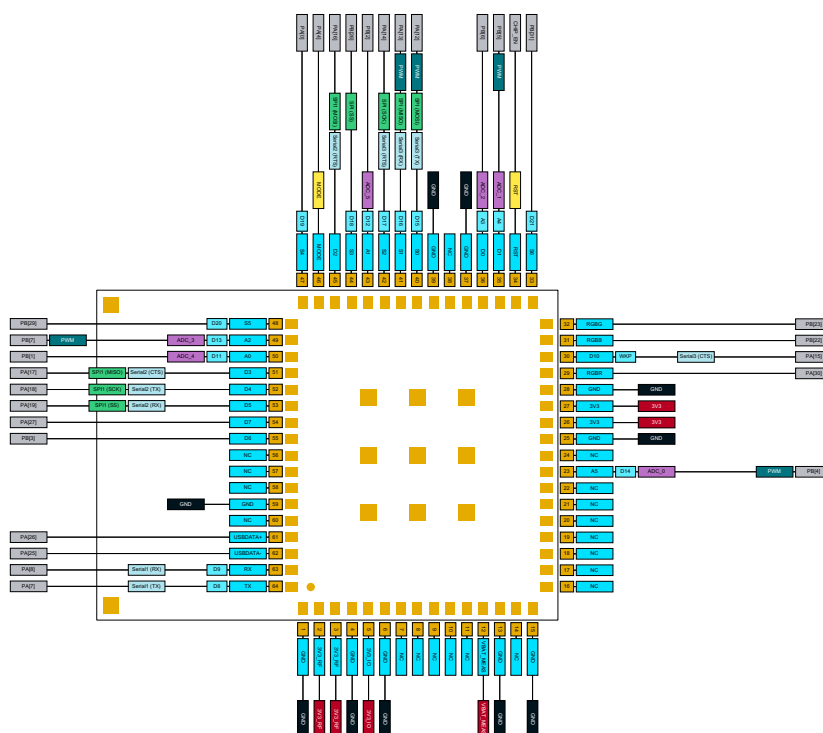

Pin	Pin Name	Description	MCU
1	GND	Ground. Be sure you connect all P1 ground pins.	
2	3V3_RF	3.3V power to RF module	
3	3V3_RF	3.3V power to RF module	
4	GND	Ground. Be sure you connect all P1 ground pins.	
5	3V3_IO	3.3V power to MCU IO.	
6	GND	Ground. Be sure you connect all P1 ground pins.	
7	NC	No connection. Do not connect anything to this pin.	
8	NC	No connection. Do not connect anything to this pin.	
9	NC	No connection. Do not connect anything to this pin.	
10	NC	No connection. Do not connect anything to this pin.	
11	NC	No connection. Do not connect anything to this pin.	
12	VBAT_MEAS	Battery voltage measurement (optional).	
13	GND	Ground. Be sure you connect all P1 ground pins.	

14	NC	No connection. Do not connect anything to this pin.	
15	GND	Ground. Be sure you connect all P1 ground pins.	
16	NC	No connection. Do not connect anything to this pin.	
17	NC	No connection. Do not connect anything to this pin.	
18	NC	No connection. Do not connect anything to this pin.	
19	NC	No connection. Do not connect anything to this pin.	
20	NC	No connection. Do not connect anything to this pin.	
21	NC	No connection. Do not connect anything to this pin.	
22	NC	No connection. Do not connect anything to this pin.	
23	A5 / D14	A5 Analog in, GPIO, PWM.	PB[4]
24	NC	No connection. Do not connect anything to this pin.	
25	GND	Ground. Be sure you connect all P1 ground pins.	
26	3V3	3.3V power to MCU	
27	3V3	3.3V power to MCU	
28	GND	Ground. Be sure you connect all P1 ground pins.	
29	RGBR	RGB LED Red. Has 10K hardware pull-up. Do not hold low at boot.	PA[30]
30	D10 / WKP	D10 GPIO, Serial 3 CTS, WKP. (Was WKP/A7 on P1.)	PA[15]
31	RGBB	RGB LED Blue	PB[22]
32	RGBG	RGB LED Green	PB[23]
33	S6 / D21	S6 GPIO, I2S WS. (Was P1S6/TESTMODE on P1.)	PB[31]
34	RST	Hardware reset. Pull low to reset; can leave unconnected in normal operation.	CHIP_EN
35	D1 / A4	D1 GPIO, PWM, I2C SCL, A4 Analog In	PB[5]
36	D0 / A3	D0 GPIO, I2C SDA, A3 Analog In	PB[6]
37	GND	Ground. Be sure you connect all P1 ground pins.	
38	NC	No connection. Do not connect anything to this pin.	
39	GND	Ground. Be sure you connect all P1 ground pins.	
40	S0 / D15	S0 GPIO, PWM, SPI MOSI, Serial3 TX, I2S MCLK. (Was P1S0 on P1.)	PA[12]
41	S1 / D16	S1 GPIO, PWM, SPI MISO, Serial3 RX. (Was P1S1 on P1.)	PA[13]
42	S2 / D17	S2 GPIO, SPI SCK, Serial3 RTS. (Was P1S2 on P1.)	PA[14]
43	A1 / D12	A1 Analog in, PDM DAT, GPIO	PB[2]
44	S3 / D18	S3 GPIO, I2S TX. (Was P1S3 on P1.), SPI SS	PB[26]
45	D2	D2 GPIO, Serial2 RTS, SPI1 MOSI	PA[16]
46	MODE	MODE button. Pin number constant is BTN. External pull-up required!	PA[4]
47	S4 / D19	S4 GPIO, I2S RX. (Was P1S4 on P1.)	PA[0]
48	S5 / D20	S5 GPIO, I2S CLK. (Was P1S5 on P1.)	PB[29]
49	A2 / D13	A2 Analog in, PWM, GPIO	PB[7]
50	A0 / D11	A0 Analog in, PDM CLK, GPIO	PB[1]
51	D3	D3 GPIO, Serial2 CTS, SPI1 MISO	PA[17]
52	D4	D4 GPIO, Serial2 TX, SPI1 SCK	PA[18]
53	D5	D5 GPIO, Serial2 RX, SPI1 SS	PA[19]
54	D7	D7 GPIO, SWDIO	PA[27]
55	D6	D6 GPIO, SWCLK	PB[3]
56	NC	No connection. Do not connect anything to this pin.	
57	NC	No connection. Do not connect anything to this pin.	
58	NC	No connection. Do not connect anything to this pin.	

59	GND	Ground. Be sure you connect all P1 ground pins.	
60	NC	No connection. Do not connect anything to this pin.	
61	USBDATA+	USB Data+	PA[26]
62	USBDATA-	USB Data-	PA[25]
63	RX / D9	Serial RX (received data), GPIO	PA[8]
64	TX / D8	Serial TX (transmitted data), GPIO	PA[7]
65	GND	Ground. Be sure you connect all P1 ground pins.	
66	GND	Ground. Be sure you connect all P1 ground pins.	
67	GND	Ground. Be sure you connect all P1 ground pins.	
68	GND	Ground. Be sure you connect all P1 ground pins.	
69	GND	Ground. Be sure you connect all P1 ground pins.	
70	GND	Ground. Be sure you connect all P1 ground pins.	
71	GND	Ground. Be sure you connect all P1 ground pins.	
72	GND	Ground. Be sure you connect all P1 ground pins.	
73	GND	Ground. Be sure you connect all P1 ground pins.	
74	NC	No connection. Do not connect anything to this pin.	
75	NC	No connection. Do not connect anything to this pin.	

COMPLETE MODULE PIN DETAILS

1 GND

Details

Pin Number	1
Pin Name	GND
Description	Ground. Be sure you connect all P1 ground pins.

2 3V3_RF

Details

Pin Number	2
Pin Name	3V3_RF
Description	3.3V power to RF module

3 3V3_RF

Details

Pin Number	3
Pin Name	3V3_RF
Description	3.3V power to RF module

4 GND

Details

Pin Number	4
Pin Name	GND
Description	Ground. Be sure you connect all P1 ground pins.

5 3V3_IO

Details

Pin Number	5
Pin Name	3V3_IO
Description	3.3V power to MCU IO.

6 GND

Details

Pin Number	6
Pin Name	GND
Description	Ground. Be sure you connect all P1 ground pins.

7 NC

Details

Pin Number	7
Pin Name	NC
Description	No connection. Do not connect anything to this pin.

8 NC

Details

Pin Number	8
Pin Name	NC
Description	No connection. Do not connect anything to this pin.

9 NC

Details

Pin Number	9
Pin Name	NC
Description	No connection. Do not connect anything to this pin.

10 NC

Details

Pin Number	10
Pin Name	NC
Description	No connection. Do not connect anything to this pin.

11 NC

Details

Pin Number	11
Pin Name	NC
Description	No connection. Do not connect anything to this pin.

12 VBAT_MEAS

Details

Pin Number	12
Pin Name	VBAT_MEAS

Description	Battery voltage measurement (optional).
Input is 5V Tolerant	Yes

13 GND

Details

Pin Number	13
Pin Name	GND
Description	Ground. Be sure you connect all P1 ground pins.

14 NC

Details

Pin Number	14
Pin Name	NC
Description	No connection. Do not connect anything to this pin.

15 GND

Details

Pin Number	15
Pin Name	GND
Description	Ground. Be sure you connect all P1 ground pins.

16 NC

Details

Pin Number	16
Pin Name	NC
Description	No connection. Do not connect anything to this pin.

17 NC

Details

Pin Number	17
Pin Name	NC
Description	No connection. Do not connect anything to this pin.

18 NC

Details

Pin Number	18
Pin Name	NC
Description	No connection. Do not connect anything to this pin.

19 NC

Details

Pin Number	19
Pin Name	NC
Description	No connection. Do not connect anything to this pin.

20 NC

Details

Pin Number	20
Pin Name	NC
Description	No connection. Do not connect anything to this pin.

21 NC

Details

Pin Number	21
Pin Name	NC
Description	No connection. Do not connect anything to this pin.

22 NC

Details

Pin Number	22
Pin Name	NC
Description	No connection. Do not connect anything to this pin.

23 A5

Details

Pin Number	23
Pin Name	A5
Pin Alternate Name	D14
Description	A5 Analog in, GPIO, PWM.
Supports digitalRead	Yes
Supports digitalWrite	Yes
Supports analogRead	Yes
Supports analogWrite (PWM)	Yes
Supports tone	Yes
Supports attachInterrupt	Yes
Internal pull resistance	42K
MCU Pin	PB[4]

24 NC

Details

Pin Number	24
Pin Name	NC
Description	No connection. Do not connect anything to this pin.

25 GND

Details

Pin Number	25
Pin Name	GND
Description	Ground. Be sure you connect all P1 ground pins.

26 3V3

Details

Pin Number	26
Pin Name	3V3
Description	3.3V power to MCU

27 3V3

Details

Pin Number	27
Pin Name	3V3
Description	3.3V power to MCU

28 GND

Details

Pin Number	28
Pin Name	GND
Description	Ground. Be sure you connect all P1 ground pins.

29 RGBR

Details

Pin Number	29
Pin Name	RGBR
Description	RGB LED Red. Has 10K hardware pull-up. Do not hold low at boot.
Supports attachInterrupt	Yes
MCU Pin	PA[30]

30 D10

Details

Pin Number	30
Pin Name	D10
Pin Alternate Name	WKP
Description	D10 GPIO, Serial 3 CTS, WKP. (Was WKP/A7 on P1.)
Supports digitalRead	Yes
Supports digitalWrite	Yes
UART serial	CTS. Use Serial3 object. Flow control optional.
Supports attachInterrupt	Yes
Internal pull resistance	2.1K
MCU Pin	PA[15]

31 RGBB

Details

Pin Number	31
Pin Name	RGBB
Description	RGB LED Blue
Supports attachInterrupt	Yes

MCU Pin	PB[22]
---------	--------

32 RGBG

Details

Pin Number	32
Pin Name	RGBG
Description	RGB LED Green
Supports attachInterrupt	Yes
MCU Pin	PB[23]

33 S6

Details

Pin Number	33
Pin Name	S6
Pin Alternate Name	D21
Description	S6 GPIO, I2S WS. (Was P1S6/TESTMODE on P1.)
Supports digitalRead	Yes
Supports digitalWrite	Yes
Supports attachInterrupt	Yes
I2S interface	WS
Internal pull resistance	22K. No internal pull up or pull down in HIBERNATE sleep mode.
MCU Pin	PB[31]

34 RST

Details

Pin Number	34
Pin Name	RST
Description	Hardware reset. Pull low to reset; can leave unconnected in normal operation.
MCU Pin	CHIP_EN

35 D1

Details

Pin Number	35
Pin Name	D1
Pin Alternate Name	A4
Description	D1 GPIO, PWM, I2C SCL, A4 Analog In
Supports digitalRead	Yes
Supports digitalWrite	Yes
Supports analogRead	Yes
Supports analogWrite (PWM)	Yes
Supports tone	Yes
I2C interface	SCL. Use Wire object. Use 1.5K to 10K external pull-up resistor.
Supports attachInterrupt	Yes
Internal pull resistance	22K
MCU Pin	PB[5]

36 D0

Details

Pin Number	36
Pin Name	D0
Pin Alternate Name	A3
Description	D0 GPIO, I2C SDA, A3 Analog In
Supports digitalRead	Yes
Supports digitalWrite	Yes
Supports analogRead	Yes
I2C interface	SDA. Use Wire object. Use 1.5K to 10K external pull-up resistor.
Supports attachInterrupt	Yes
Internal pull resistance	22K
MCU Pin	PB[6]

37 GND

Details

Pin Number	37
Pin Name	GND
Description	Ground. Be sure you connect all P1 ground pins.

38 NC

Details

Pin Number	38
Pin Name	NC
Description	No connection. Do not connect anything to this pin.

39 GND

Details

Pin Number	39
Pin Name	GND
Description	Ground. Be sure you connect all P1 ground pins.

40 S0

Details

Pin Number	40
Pin Name	S0
Pin Alternate Name	D15
Description	S0 GPIO, PWM, SPI MOSI, Serial3 TX, I2S MCLK. (Was P1S0 on P1.)
Supports digitalRead	Yes
Supports digitalWrite	Yes
Supports analogWrite (PWM)	Yes
Supports tone	Yes
UART serial	TX. Use Serial3 object.
SPI interface	MOSI. Use SPI object.
Supports attachInterrupt	Yes

I2S interface	MCLK
Internal pull resistance	2.1K
MCU Pin	PA[12]

41 S1

Details

Pin Number	41
Pin Name	S1
Pin Alternate Name	D16
Description	S1 GPIO, PWM, SPI MISO, Serial3 RX. (Was P1S1 on P1.)
Supports digitalRead	Yes
Supports digitalWrite	Yes
Supports analogWrite (PWM)	Yes
Supports tone	Yes
UART serial	RX. Use Serial3 object.
SPI interface	MISO. Use SPI object.
Supports attachInterrupt	Yes
Internal pull resistance	2.1K
MCU Pin	PA[13]

42 S2

Details

Pin Number	42
Pin Name	S2
Pin Alternate Name	D17
Description	S2 GPIO, SPI SCK, Serial3 RTS. (Was P1S2 on P1.)
Supports digitalRead	Yes
Supports digitalWrite	Yes
UART serial	RTS. Use Serial3 object. Flow control optional.
SPI interface	SCK. Use SPI object.
Supports attachInterrupt	Yes
Internal pull resistance	2.1K
MCU Pin	PA[14]

43 A1

Details

Pin Number	43
Pin Name	A1
Pin Alternate Name	D12
Description	A1 Analog in, PDM DAT, GPIO
Supports digitalRead	Yes
Supports digitalWrite	Yes
Supports analogRead	Yes
Supports attachInterrupt	Yes
Internal pull resistance	2.1K

MCU Pin PB[2]

44 S3

Details

Pin Number	44
Pin Name	S3
Pin Alternate Name	D18
Description	S3 GPIO, I2S TX. (Was P1S3 on P1.), SPI SS
Supports digitalRead	Yes
Supports digitalWrite	Yes
SPI interface	Default SS for SPI.
Supports attachInterrupt	Yes
I2S interface	TX
Internal pull resistance	2.1K
MCU Pin	PB[26]

45 D2

Details

Pin Number	45
Pin Name	D2
Description	D2 GPIO, Serial2 RTS, SPI1 MOSI
Supports digitalRead	Yes
Supports digitalWrite	Yes
UART serial	RTS. Use Serial2 object. Flow control optional.
SPI interface	MOSI. Use SPI1 object.
Supports attachInterrupt	Yes
Internal pull resistance	2.1K
MCU Pin	PA[16]

46 MODE

Details

Pin Number	46
Pin Name	MODE
Description	MODE button. Pin number constant is BTN. External pull-up required!
Supports attachInterrupt	Yes
MCU Pin	PA[4]

47 S4

Details

Pin Number	47
Pin Name	S4
Pin Alternate Name	D19
Description	S4 GPIO, I2S RX. (Was P1S4 on P1.)
Supports digitalRead	Yes
Supports digitalWrite	Yes

Supports attachInterrupt	Yes
I2S interface	RX
Internal pull resistance	22K. No internal pull up or pull down in HIBERNATE sleep mode.
MCU Pin	PA[0]

48 S5

Details

Pin Number	48
Pin Name	S5
Pin Alternate Name	D20
Description	S5 GPIO, I2S CLK. (Was P1S5 on P1.)
Supports digitalWrite	Yes
Supports attachInterrupt	Yes
I2S interface	CLK
Internal pull resistance	22K. No internal pull up or pull down in HIBERNATE sleep mode
MCU Pin	PB[29]

49 A2

Details

Pin Number	49
Pin Name	A2
Pin Alternate Name	D13
Description	A2 Analog in, PWM, GPIO
Supports digitalRead	Yes
Supports digitalWrite	Yes
Supports analogRead	Yes
Supports analogWrite (PWM)	Yes
Supports tone	Yes
Supports attachInterrupt	Yes
Internal pull resistance	42K
MCU Pin	PB[7]

50 A0

Details

Pin Number	50
Pin Name	A0
Pin Alternate Name	D11
Description	A0 Analog in, PDM CLK, GPIO
Supports digitalRead	Yes
Supports digitalWrite	Yes
Supports analogRead	Yes
Supports attachInterrupt	Yes
Internal pull resistance	2.1K
MCU Pin	PB[1]

51 D3**Details**

Pin Number	51
Pin Name	D3
Description	D3 GPIO, Serial2 CTS, SPI1 MISO
Supports digitalRead	Yes
Supports digitalWrite	Yes
UART serial	CTS. Use Serial2 object. Flow control optional.
SPI interface	MISO. Use SPI1 object.
Supports attachInterrupt	Yes
Internal pull resistance	2.1K
MCU Pin	PA[17]

52 D4**Details**

Pin Number	52
Pin Name	D4
Description	D4 GPIO, Serial2 TX, SPI1 SCK
Supports digitalRead	Yes
Supports digitalWrite	Yes
UART serial	TX. Use Serial2 object.
SPI interface	SCK. Use SPI1 object.
Supports attachInterrupt	Yes
Internal pull resistance	2.1K
MCU Pin	PA[18]

53 D5**Details**

Pin Number	53
Pin Name	D5
Description	D5 GPIO, Serial2 RX, SPI1 SS
Supports digitalRead	Yes
Supports digitalWrite	Yes
UART serial	RX. Use Serial2 object.
SPI interface	SS. Use SPI1 object. Can use any pin for SPI1 SS/CS however.
Supports attachInterrupt	Yes
Internal pull resistance	2.1K
MCU Pin	PA[19]

54 D7**Details**

Pin Number	54
Pin Name	D7
Description	D7 GPIO, SWDIO
Supports digitalRead	Yes.

Supports digitalWrite	Yes. On the Photon this is the blue D7 LED.
Supports attachInterrupt	Yes
Internal pull resistance	42K
SWD interface	SWDIO. 40K pull-up at boot.
Signal used at boot	SWDIO. 40K pull-up at boot. Low at boot triggers MCU test mode.
MCU Pin	PA[27]

55 D6

Details

Pin Number	55
Pin Name	D6
Description	D6 GPIO, SWCLK
Supports digitalRead	Yes
Supports digitalWrite	Yes
Supports attachInterrupt	Yes
Internal pull resistance	42K
SWD interface	SWCLK. 40K pull-down at boot.
Signal used at boot	SWCLK. 40K pull-down at boot.
MCU Pin	PB[3]

56 NC

Details

Pin Number	56
Pin Name	NC
Description	No connection. Do not connect anything to this pin.

57 NC

Details

Pin Number	57
Pin Name	NC
Description	No connection. Do not connect anything to this pin.

58 NC

Details

Pin Number	58
Pin Name	NC
Description	No connection. Do not connect anything to this pin.

59 GND

Details

Pin Number	59
Pin Name	GND
Description	Ground. Be sure you connect all P1 ground pins.

60 NC

Details

Pin Number	60
Pin Name	NC
Description	No connection. Do not connect anything to this pin.

61 USBDATA+

Details

Pin Number	61
Pin Name	USBDATA+
Description	USB Data+
Input is 5V Tolerant	Yes
MCU Pin	PA[26]

62 USBDATA-

Details

Pin Number	62
Pin Name	USBDATA-
Description	USB Data-
Input is 5V Tolerant	Yes
MCU Pin	PA[25]

63 RX

Details

Pin Number	63
Pin Name	RX
Pin Alternate Name	D9
Description	Serial1 RX (received data), GPIO
Supports digitalRead	Yes
Supports digitalWrite	Yes
UART serial	RX. Use Serial1 object.
Supports attachInterrupt	Yes
Internal pull resistance	42K
MCU Pin	PA[8]

64 TX

Details

Pin Number	64
Pin Name	TX
Pin Alternate Name	D8
Description	Serial1 TX (transmitted data), GPIO
Supports digitalRead	Yes
Supports digitalWrite	Yes
UART serial	TX. Use Serial1 object.
Supports attachInterrupt	Yes
Internal pull resistance	42K

Signal used at boot	Low at boot triggers ISP flash download
MCU Pin	PA[7]

65 GND

Details

Pin Number	65
Pin Name	GND
Description	Ground. Be sure you connect all P1 ground pins.

66 GND

Details

Pin Number	66
Pin Name	GND
Description	Ground. Be sure you connect all P1 ground pins.

67 GND

Details

Pin Number	67
Pin Name	GND
Description	Ground. Be sure you connect all P1 ground pins.

68 GND

Details

Pin Number	68
Pin Name	GND
Description	Ground. Be sure you connect all P1 ground pins.

69 GND

Details

Pin Number	69
Pin Name	GND
Description	Ground. Be sure you connect all P1 ground pins.

70 GND

Details

Pin Number	70
Pin Name	GND
Description	Ground. Be sure you connect all P1 ground pins.

71 GND

Details

Pin Number	71
Pin Name	GND
Description	Ground. Be sure you connect all P1 ground pins.

72 GND

Details

Pin Number 72

Pin Name GND

Description Ground. Be sure you connect all P1 ground pins.

73 GND

Details

Pin Number 73

Pin Name GND

Description Ground. Be sure you connect all P1 ground pins.

74 NC

Details

Pin Number 74

Pin Name NC

Description No connection. Do not connect anything to this pin.

75 NC

Details

Pin Number 75

Pin Name NC

Description No connection. Do not connect anything to this pin.

Technical specification

RECOMMENDED OPERATING CONDITIONS

Parameter	Symbol	Min	Typ	Max	Unit
Operating Temperature	T_{op}	-20		+70	°C
Humidity Range				95	%

I/O CHARACTERISTICS

Parameter	Symbol	Min	Typ	Peak	Unit
Input-High Voltage	V_{IH}	2.0			V
Input-Low Voltage	V_{IL}			0.8	V
Output drive strength (normal drive)				4	mA
Output drive strength (high drive)				12	mA
Total output drive (all pins)				200	mA

POWER CONSUMPTION

Parameter	Symbol	Min	Typ	Peak	Unit
Operating Current (uC on, peripherals and radio disabled)	I_{idle}	63.8	65.8	68.9	mA
Operating Current (uC on, BLE advertising)	I_{ble_adv}	62.4	66.1	73.8	mA
Operating Current (uC on, radio connected to access point)	$I_{wifi_conn_ap}$	62.3	67.8	325	mA
STOP mode sleep, GPIO wake-up	I_{stop_gpio}	549	579	608	uA
STOP mode sleep, time wake-up	I_{stop_intrtc}	543	572	604	uA
ULP mode sleep, GPIO wake-up	I_{ulp_gpio}	549	579	608	uA
ULP mode sleep, time wake-up	I_{ulp_intrtc}	543	572	604	uA
HIBERNATE mode sleep, GPIO wake-up	I_{hib_gpio}	93.8	114	133	uA
HIBERNATE mode sleep, time wake-up	I_{hib_intrtc}	93.3	115	133	uA

¹The min, and particularly peak, values may consist of very short transients. The typical (typ) values are the best indicator of overall power consumption over time. The peak values indicate the absolute minimum capacity of the power supply necessary, not overall consumption.

Mechanical specifications

MODULE DIMENSIONS

- P2 module dimensions are: 0.787"(28mm) (W) x 1.102"(20mm) (L) x 0.118"(3.0mm) (H) +/-0.0039" (0.1mm) (includes metal shielding)

RECOMMENDED PCB LAND PATTERN

The P2 can be mounted directly on a carrier PCB with following PCB land pattern:

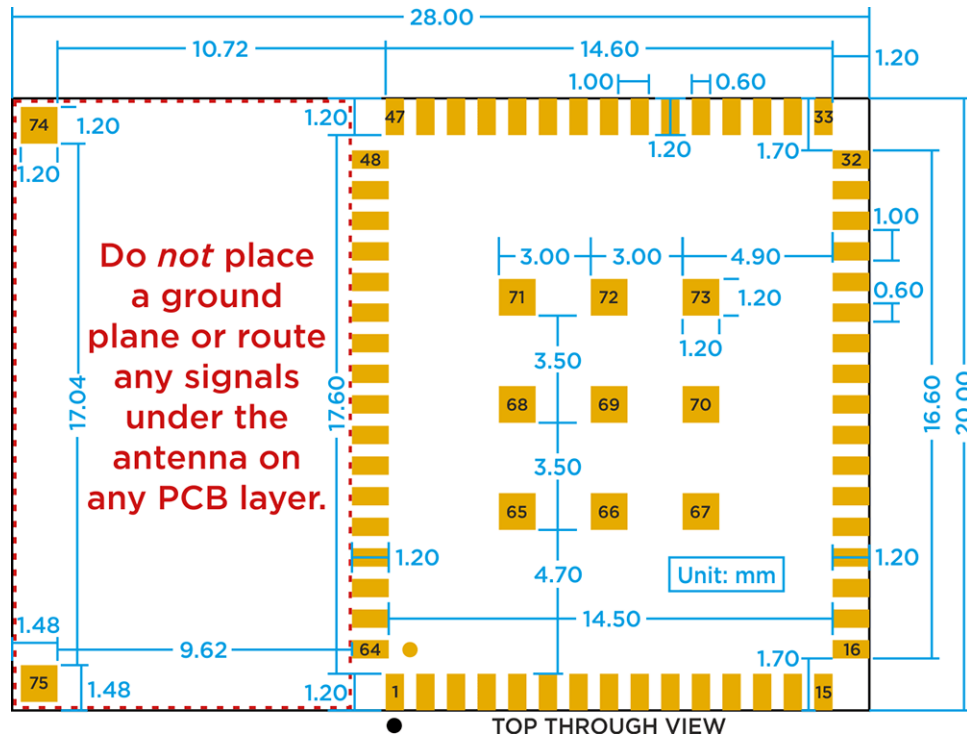

A P1/P2 part for EAGLE can be found in the [Particle EAGLE library](#).

When laying out your board:

- The area in the component keep-out (1) must be free of ground plane, traces, and components on the top or bottom of the board. This will be enforced by Eagle CAD.
- Avoid having a strip of ground plane next to the antenna (2). This is easy to do accidentally, and should be avoided.
- When possible, avoid ground plane in area (3). If you need to put traces or components in this area, it can be done if there is no convenient alternative, but it's best to keep the area close to the antenna as empty as possible for best RF performance.

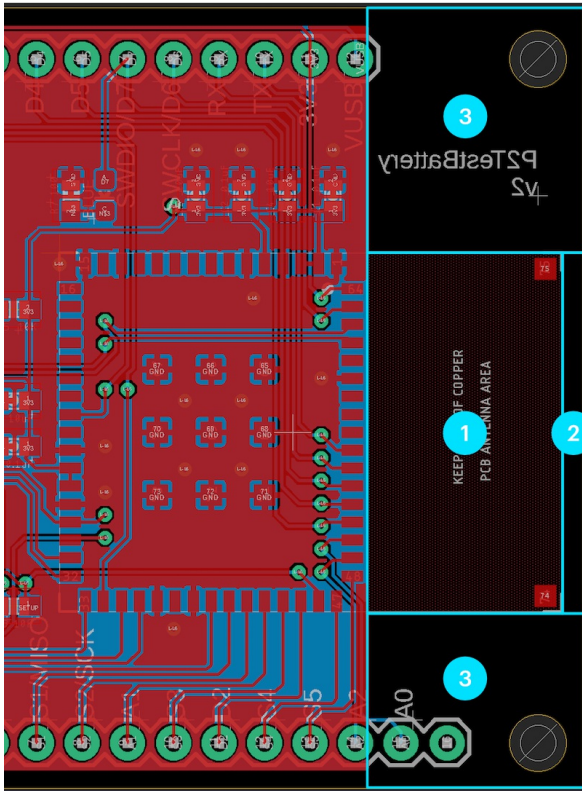

3D MODELS

3D models of the P2 module are available in the [hardware-libraries Github](#) in formats including step, iges, and f3z.

Reference design

A [P2 reference design](#) is available in Github. The repository includes schematics, board layout, footprints, for Eagle CAD.

Recommended solder reflow profile

[This information is from the P1, and is likely to remain the same, but is subject to change.]

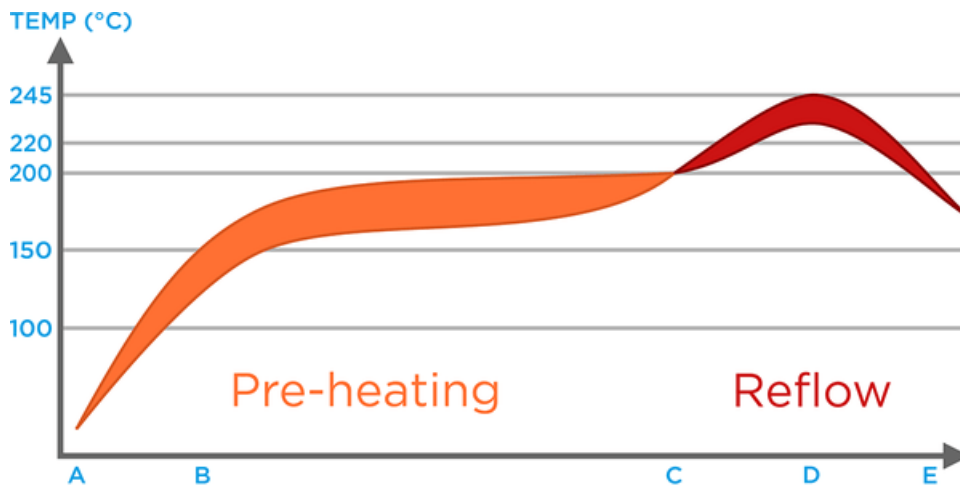

Phase Temperatures and Rates

A-B.	Ambient - 150°C, Heating rate: < 3°C/s
B-C.	150 - 200°C, soak time: 60 - 120 s
C-D.	200 - 245°C, Heating rate: < 3°C/s
D.	Peak temp.: 235 - 245°C, Time above 220°C: 40 - 90 s
D-E.	245 - 220°C, Cooling rate: < 1°C/s

Ordering information

P2 modules are available from store.particle.io as cut tape in quantities of 10 each.

SKU	Description	Region	Lifecycle	Replacement
P2MOD10	P2 Wi-Fi Module, Cut tape [x10]	Global	GA	
P2REEL	P2 Wi-Fi Module, Reel [x600]	Global	GA	

Qualification and approvals



- RoHS
- CE
- FCC ID: 2AEMI-P2
- ISED: 20127-P2

Product handling

MOISTURE SENSITIVITY LEVELS

The Moisture Sensitivity Level (MSL) relates to the packaging and handling precautions required. The P1 module is rated level 3. In general, this precaution applies for Photons without headers. When reflowing a P1 directly onto an application PCB, increased moisture levels prior to reflow can damage sensitive electronics on the P1. A bake process to reduce moisture may be required.

For more information regarding moisture sensitivity levels, labeling, storage and drying see the MSL standard see IPC/JEDEC J-STD-020 (can be downloaded from www.jedec.org).

ESD PRECAUTIONS

The P1 module contains highly sensitive electronic circuitry and is an Electrostatic Sensitive Device (ESD). Handling a P1 module without proper ESD protection may destroy or damage it permanently. Proper ESD handling and packaging procedures must be applied throughout the processing, handling and operation of any application that incorporates P1 modules. ESD precautions should be implemented on the application board where the P1 module is mounted. Failure to observe these precautions can result in severe damage to the P1 module!

Assembly

WATER SOLUBLE FLUX

Water soluble flux should not be used with the P2 module. There are components within the module that are moisture-sensitive, and wash water can get trapped under the RF shields, causing damage.

Use no-clean flux instead.

CONFORMAL COATINGS

We do not recommend using a conformal coating on the P2 module to protect the module from water. Some components on the module cannot be coated and would need to be masked off during coating. This will make the coating process difficult to implement and test.

Using an enclosure that protects both your base board and the P2 module as a single waterproof assembly is recommended instead.

Default settings

The P2 module comes pre-programmed with a bootloader and a user application called Tinker. This application works with an iOS and Android app also named Tinker that allows you to very easily toggle digital pins, take analog and digital readings and drive variable PWM outputs.

The bootloader allows you to easily update the user application via several different methods, USB, OTA, Serial Y-Modem, and also internally via the Factory Reset procedure. All of these methods have multiple tools associated with them as well.

You may use the [Particle Web IDE](#) to code, compile and flash a user application OTA (Over The Air). [Particle Workbench](#) is a full-featured desktop IDE for Windows, Mac, and Linux based on VSCode and supports both cloud-based and local gcc-arm compiles. The [Particle CLI](#) provides a command-line interface for cloud-based compiles and flashing code over USB.

Intended applications

The P2 module is intended to be used for Wi-Fi based Internet-of-Things (IoT) applications such as environment, weather, HVAC, equipment, and security monitoring.

The P2 is not certified for use as a wearable device.

Glossary

Radio Frequency

SMT

Surface Mount Technology (often associated with SMD which is a surface mount device).

AP

Access Point

USB

Universal Serial Bus

Quiescent current

Current consumed in the deepest sleep state

FT

Five-tolerant; Refers to a pin being tolerant to 5V.

3V3

+3.3V; The regulated +3.3V supply rail. Also used to note a pin is only 3.3V tolerant.

RTC

Real Time Clock

OTA

Over The Air; describing how firmware is transferred to the device.

FCC ISED CE warnings and end product labeling requirements

The FCC, ISED, and CE certifications are radio module certifications only. Additional certification will be required for your completed system.

UNITED STATES (FCC)

Federal Communication Commission Interference Statement This equipment has been tested and found to comply with the limits for a Class B digital device, pursuant to Part 15 of the FCC Rules. These limits are designed to provide reasonable protection against harmful interference in a residential installation. This equipment generates, uses and can radiate radio frequency energy and, if not installed and used in accordance with the instructions, may cause harmful interference to radio communications. However, there is no guarantee that interference will not occur in a particular installation. If this equipment does cause harmful interference to radio or television reception, which can be determined by turning the equipment off and on, the user is encouraged to try to correct the interference by one of the following measures:

- Reorient or relocate the receiving antenna.
- Increase the separation between the equipment and receiver.
- Connect the equipment into an outlet on a circuit different from that to which the receiver is connected.
- Consult the dealer or an experienced radio/TV technician for help.

FCC Caution: Any changes or modifications not expressly approved by the party responsible for compliance could void the user's authority to operate this equipment. This device complies with Part 15 of the FCC Rules. Operation is subject to the following two conditions:

1. This device may not cause harmful interference, and
2. This device must accept any interference received, including interference that may cause undesired operation.

FCC Radiation Exposure Statement: This equipment complies with FCC radiation exposure limits set forth for an uncontrolled environment. This transmitter module must not be co-located or operating in conjunction with any other antenna or transmitter. This End equipment should be installed and operated with a minimum distance of 20 centimeters between the radiator and your body.

IMPORTANT NOTE: In the event that these conditions can not be met (for example certain laptop configurations or co-location with another transmitter), then the FCC authorization is no longer considered valid and the FCC ID can not be used on the final product. In these circumstances, the OEM integrator will be responsible for re-evaluating the end product (including the transmitter) and obtaining a separate FCC authorization.

End Product Labeling The final end product must be labeled in a visible area with the following:

Contains FCC ID: 2AEMI-P2

Manual Information to the End User The OEM integrator has to be aware not to provide information to the end user regarding how to install or remove this RF module in the user's manual of the end product which integrates this module.

Outdoor Use (US)

To be compliant to FCC §15.407(a) the EIRP is not allowed to exceed 125 mW (21 dBm) at any elevation angle above 30° (measured from the horizon) when operated as an outdoor access point in U-NII-1 band, 5.150-5.250 GHz.

Canada Statement This device complies with Industry Canada's licence-exempt RSSs. Operation is subject to the following two conditions:

1. This device may not cause interference; and
2. This device must accept any interference, including interference that may cause undesired operation of the device.

Le présent appareil est conforme aux CNR d'Industrie Canada applicables aux appareils radio exempts de licence.

L'exploitation est autorisée aux deux conditions suivantes:

1. l'appareil ne doit pas produire de brouillage;
2. l'utilisateur de l'appareil doit accepter tout brouillage radioélectrique subi, même si le brouillage est susceptible d'en compromettre le fonctionnement.

Caution Exposure: This device meets the exemption from the routine evaluation limits in section 2.5 of RSS102 and users can obtain Canadian information on RF exposure and compliance. Le dispositif répond à l'exemption des limites d'évaluation de routine dans la section 2.5 de RSS102 et les utilisateurs peuvent obtenir des renseignements canadiens sur l'exposition aux RF et le respect.

The final end product must be labelled in a visible area with the following: The Industry Canada certification label of a module shall be clearly visible at all times when installed in the host device, otherwise the host device must be labelled to display the Industry Canada certification number of the module, preceded by the words "Contains transmitter module", or the word "Contains", or similar wording expressing the same meaning, as follows:

Contains transmitter module ISED: 20127-P2

This End equipment should be installed and operated with a minimum distance of 20 centimeters between the radiator and your body. Cet équipement devrait être installé et actionné avec une distance minimum de 20 centimètres entre le radiateur et votre corps.

The end user manual shall include all required regulatory information/warning as shown in this manual.

Outdoor use (CA)

- Operation in the band 5150–5250 MHz is only for indoor use to reduce the potential for harmful interference to co-channel mobile satellite systems;
- Operation in the 5600-5650 MHz band is not allowed in Canada. High-power radars are allocated as primary users (i.e., priority users) of the bands 5250-5350 MHz and 5650-5850 MHz and that these radars could cause interference and/or damage to LE-LAN devices.

- Le dispositif de fonctionnement dans la bande 5150-5250 MHz est réservé à une utilisation en intérieur pour réduire le risque d'interférences nuisibles à la co-canal systèmes mobiles par satellite
- Opération dans la bande 5600-5650 MHz n'est pas autorisée au Canada. Haute puissance radars sont désignés comme utilisateurs principaux (c.-à-utilisateurs prioritaires) des bandes 5250-5350 MHz et 5650-5850 MHz et que ces radars pourraient causer des interférences et / ou des dommages à dispositifs LAN-EL.

EUROPEAN UNION (CE)

We, Particle Industries, Inc, declare under our sole responsibility that the product, P2, to which this declaration relates, is in conformity with RED Directive 2014/53/EU and (EU) 2015/863 RoHS Directive 2011/65/EU (Recast).

The full text of the EU declaration of conformity is available at the following Internet address:

<https://www.particle.io/>

Radiation Exposure Statement: This equipment complies with radiation exposure limits set forth for an uncontrolled environment.

The operating frequency bands and the maximum transmitted power limit are listed below:

- BLE 2402-2480MHz 10dBm
- Wi-Fi 2.4GHz band 2412-2484MHz 20dBm
- Wi-Fi 5GHz band 5180-5825MHz 23dBm

UNITED KINGDOM

UKCA Conformity:

Radio Equipment Regulations 2017 (S.I. 2017/1206)

OUTDOOR USE (WORLD)

This device is restricted to indoor use when operating in the 5150 to 5350 MHz frequency range.

This restriction applies in: AT, BE, BG, CH, CY, CZ, DE, DK, EE, EL, ES, FI, FR, HR, HU, IE, IS, IT, LI, LT, LU, LV, MT, NL, NO, PL, PT, RO, SE, SI, SK, TR, UA, UK(NI).

Certification documents

BLUETOOTH - P2

- [Bluetooth RF Test Report](#)
- [Bluetooth Profile and Service Test Report](#)
- [Bluetooth Module Submission](#)

CE (EUROPE) - P2

- [Certificate of Conformity](#)
- [EN 300-328 Bluetooth LE Test Report](#)
- [EN 300-328 Wi-Fi Test Report](#)
- [EN 300-440 Wi-Fi 5 GHz Test Report](#)
- [EN 301-489 Test Report](#)
- [EN 301-893 Wi-Fi 5 GHz Test Report](#)
- [EN 301-893 Dynamic Frequency Selection DFS Test Report](#)
- [EN62311 Test Report](#)
- [EN62368 Test Report](#)
- [EN62479 Test Report](#)

FCC (UNITED STATES) - P2

- FCC ID: 2AEMI-P2
- [FCC Grant of Equipment Authorization \(DTS\)](#)
- [FCC Grant of Equipment Authorization \(NII\)](#)
- [RF Exposure Report FCC Part 2, Section 2.1091](#)
- [FCC 15.247 Bluetooth LE Test Report](#)
- [FCC 15.247 Wi-Fi Test Report](#)
- [FCC 15.407 Test Report](#)
- [FCC 15.407 Test Report \(5 GHz Wi-Fi\)](#)

ISED (CANADA) - P2

- ISED: **20127-P2**
- [Certificate of Conformity](#)
- [ISED RSS-247 BTLE Test Report](#)
- [ISED RSS-247 Wi-Fi 2.4 GHz Test Report](#)
- [ISED RSS-247 Wi-Fi 5 GHz Test Report](#)
- [ISED RSS-247 DFS Test Report;](#)
- [ISED RSS-102 RF Exposure Report](#)

ROHS - P2

- [RoHS Test Report](#)

UKCA (UNITED KINGDOM) - P2

- [UKCA Certification](#)

Revision history

Revision	Date	Author	Comments
pre	2021-11-04	RK	Pre-release
	2022-02-08	RK	Corrected D pin aliases for A5 and S0-S6
	2022-02-25	RK	Changed D pin aliases for D9 - D22, A5 is not SPI MOSI, Serial2 TX and RX were reversed
	2022-03-14	RK	Minor edits; no functional changes
	2022-03-23	RK	Added FCC and ISED IDs, operating temperature range
	2022-04-12	RK	Added serial baud rates
	2022-04-16	RK	Added Serial3
	2022-05-07	RK	Temperature range is -20°C to +70°C
	2022-05-27	RK	Updated antenna information, rendering
	2022-06-03	RK	Added note about module certification
	2022-06-08	RK	Added intended applications section, changed reference to ARM M4F to M33
	2022-06-29	RK	Added flash memory map
	2022-07-14	RK	No hardware pull-up on MODE pin
	2022-07-22	RK	Added power consumption
	2022-08-12	RK	Added listing of pins used at boot
	2022-08-12	RK	Warning about BLE central mode not available
	2022-08-18	RK	EU certification statement
	2022-09-16	RK	Added UKCA conformity
	2022-11-08	RK	Added external antenna
	2022-11-16	RK	Added additional board layout tips
	2022-11-17	RK	Pin D0 does not have PWM
	2022-12-16	RK	Added warning about using RGBR as GPIO because of the 10K pull-up
	2023-01-31	RK	Add Device OS versions
001	2023-03-08	RK	Main CPU (KM4) is M33, not M23
002	2023-03-14	RK	Added power supply specifications
003	2023-04-05	RK	Added Device OS 5.3.1 information for SPI and retained memory
004	2023-04-10	RK	Outdoor use restrictions
005	2023-04-24	RK	Document VBAT_MEAS
006	2023-04-28	RK	Add conformal coating and flux notes

007	2023-05-05	RK	Update available RAM
008	2023-05-11	RK	Add link to reference design
009	2023-06-07	RK	Add module height (3mm)
010	2023-07-07	RK	Add supervisory reset IC recommendation
011	2023-09-08	RK	Add 5V tolerance section
012	2023-11-13	RK	Add full pin details
013	2023-12-20	RK	Add boot mode pin information to GPIO pin listing
014	2024-02-20	RK	Added pin drive strength
015	2024-03-11	RK	Added boot mode pin warning to GPIO pin table
016	2024-04-18	RK	Add PDM microphone
017	2024-04-23	RK	Added links to certification documents
018	2024-04-25	RK	Update retained memory description
019	2024-04-25	RK	Added I/O characteristics

Known errata

Contact

Web

<https://www.particle.io>

Community Forums

<https://community.particle.io>