

TEST REPORT



Applicant	Particle Industries, Inc
Address	325 9th Street, San Francisco, CA 94103 United States

Manufacturer or Supplier	Particle Industries, Inc	
Address	325 9th Street, San Francisco, CA 94103 United States	
Product	Wi-Fi Module	
Brand Name	Particle	
Model	P2	
Additional Model & Model Difference	N/A	
Date of tests	Feb. 21, 2021 ~ Apr. 08, 2022	

The submitted sample of the above equipment has been tested according to the requirements of the following standard:

EN 300 440 V2.2.1 (2018-07)

CONCLUSION: The submitted sample was found to COMPLY with the test requirement

<p>Tested by Lucas Chen Project Engineer / EMC Department</p>	<p>Approved by Glyn He Assistant Manager / EMC Department</p>
	
<p>Date: Jul. 18, 2022</p>	

This report is governed by, and incorporates by reference, the Conditions of Testing as posted at the date of issuance of this report at <http://www.bureauveritas.com/home/about-us/our-business/cps/about-us/terms-conditions/> and is intended for your exclusive use. Any copying or replication of this report to or for any other person or entity, or use of our name or trademark, is permitted only with our prior written permission. This report sets forth our findings solely with respect to the test samples identified herein. The results set forth in this report are not indicative or representative of the quality or characteristics of the lot from which a test sample was taken or any similar or identical product unless specifically and expressly noted. Our report includes all of the tests requested by you and the results thereof based upon the information that you provided to us. Measurement uncertainty is only provided upon request for accredited tests. Statements of conformity are based on simple acceptance criteria without taking measurement uncertainty into account, unless otherwise requested in writing. You have 60 days from date of issuance of this report to notify us of any material error or omission caused by our negligence or if you require measurement uncertainty; provided, however, that such notice shall be in writing and shall specifically address the issue you wish to raise. A failure to raise such issue within the prescribed time shall constitute your unqualified acceptance of the completeness of this report, the tests conducted and the correctness of the report contents.



TABLE OF CONTENTS

RELEASE CONTROL RECORD 4

1 SUMMARY OF TEST RESULTS 5

1.1 TEST INSTRUMENTS 7

1.2 MEASUREMENT UNCERTAINTY 9

1.3 MAXIMUM MEASUREMENT UNCERTAINTY 9

2 GENERAL INFORMATION..... 10

2.1 GENERAL DESCRIPTION OF EUT 10

2.2 DESCRIPTION OF TEST MODES 12

2.3 GENERAL DESCRIPTION OF APPLIED STANDARDS 12

2.4 DESCRIPTION OF SUPPORT UNITS 12

3 TEST TYPES AND RESULTS 13

TRANSMITTER PARAMETERS 13

3.1 EQUIVALENT ISOTROPIC RADIATED POWER 13

3.1.1 LIMITS OF EQUIVALENT ISOTROPIC RADIATED POWER 13

3.1.2 TEST PROCEDURES 13

3.1.3 DEVIATION FROM TEST STANDARD 13

3.1.4 TEST SETUP 13

3.1.5 TEST RESULTS 14

3.2 PERMITTED RANGE OF OPERATING FREQUENCIES 17

3.2.1 LIMITS OF PERMITTED RANGE OF OPERATING FREQUENCIES 17

3.2.2 TEST PROCEDURES 17

3.2.3 DEVIATION FROM TEST STANDARD 17

3.2.4 TEST SETUP 17

3.2.5 TEST RESULTS 18

3.3 MEASUREMENT RADIATED SPURIOUS EMISSION 20

3.3.1 LIMITS OF MEASUREMENT RADIATED SPURIOUS EMISSION 20

3.3.2 TEST PROCEDURES 20

3.3.3 DEVIATION FROM TEST STANDARD 20

3.3.4 TEST SETUP 20

3.3.5 TEST RESULTS 21

3.4 DUTY CYCLE (NOT APPLY) 25

3.4.1 LIMITS OF DUTY CYCLE 25

3.4.2 TEST PROCEDURES 25

3.4.3 DEVIATION FROM TEST STANDARD 25

3.4.4 TEST SETUP 25

3.4.5 TEST RESULTS 25

RECEIVER PARAMETERS 26

3.5 LIMITES OF ADJACENT CHANNEL SELECTIVITY 26

3.5.1 TEST PROCEDURES 26

3.5.2 TEST SETUP 27

3.5.3 TEST RESULTS 27

3.6 BLOCKING OR DESENSITIZATION 28

3.6.1 LIMITES OF RECEIVER BLOCKING 28

3.6.2 TEST PROCEDURES 28

3.6.3 TEST SETUP 28

3.6.4 TEST RESULTS 29

3.7 RECEIVER SPURIOUS EMISSIONS 31



**BUREAU
VERITAS**

Test Report No.: RE2207WDG0104-3

3.7.1	LIMITS OF RECEIVER SPURIOUS EMISSIONS.....	31
3.7.2	TEST PROCEDURES	31
3.7.3	DEVIATION FROM TEST STANDARD	31
3.7.4	TEST SETUP.....	31
3.7.5	TEST RESULTS	32
4	PHOTOGRAPHS OF THE TEST CONFIGURATION	35
5	APPENDIX A – MODIFICATIONS RECORDERS FOR ENGINEERING CHANGES TO THE EUT BY THE LAB.....	36



BUREAU
VERITAS

Test Report No.: RE2207WDG0104-3

RELEASE CONTROL RECORD

ISSUE NO.	REASON FOR CHANGE	DATE ISSUED
RE2202WDG0092-3	Original release	May 19, 2022
RE2207WDG0104-3	Based on the original report RE2202WDG0092-3 updated the label, but it doesn't need to be retested.	Jul. 18, 2022



1 SUMMARY OF TEST RESULTS

The EUT has been tested according to the following specifications:

APPLIED STANDARD: EN 300 440 V2.2.1 (2018-07)			
Standard Subclause	Test Type and Limit	Result	Remark
	TRANSMITTER PARAMETERS		
4.2.2	Equivalent Isotropic Radiated Power	PASS	Applicable
4.2.3	Permitted range of operating frequency	PASS	Applicable
4.2.4	Unwanted emissions in the spurious domain	PASS	Applicable
4.2.5	Duty Cycle	N/A	Not Applicable
	RECEIVER PARAMETERS		
4.3.3	Adjacent channel selectivity	N/A	Not Applicable
4.3.4	Blocking or desensitization	PASS	Applicable
4.3.5	Radiated spurious emission	PASS	Applicable



Receiver categories

Receiver category	Relevant receiver clauses	Risk assessment of receiver performance	The EUT Category
1	4.3.3, 4.3.4 and 4.3.5	Highly reliable SRD communication media; e.g. serving human life inherent systems (may result in a physical risk to a person).	-
2	4.3.4 and 4.3.5	Medium reliable SRD communication media e.g. causing inconvenience to persons, which cannot simply be overcome by other means.	-
3	4.3.4 and 4.3.5	Standard reliable SRD communication media e.g. Inconvenience to persons, which can simply be overcome by other means (e.g. manual).	√

If receiver category 1 or 2 is selected, this shall be stated in both the test report and in the user's manual for the equipment.



1.1 TEST INSTRUMENTS

Equipment	Manufacturer	Model No.	Serial No.	Next Cal.
EMI Test Receiver	Rohde&Schwarz	ESU40	100449	Mar. 07, 23
Signal and Spectrum Analyzer	Rohde&Schwarz	FSV40	101094	Jan. 16, 23
Bilog Antenna	Teseq	CBL 6111D	30643	May 21, 22
Horn Antenna	ETS-Lindgren	3117	00062558	May 21, 22
GPS Generator+ Antenna	TOJOIN	GNSS-5000A	E1-010119	N/A
3m Semi-anechoic Chamber	ETS-LINDGREN	9m*6m*6m	NSEMC003	May 22, 22
Test Software	ADT	ADT_Radiated_V 7.6.15.9.2	N/A	N/A
Test software	ADT	ADT_RF Test Software V6.6.5.3	N/A	N/A
Horn Antenna (15GHz-40GHz)	SCHWARZBECK	BBHA 9170	BBHA9170147	May 14, 22
Amplifier	Burgeon	BPA-530	100220	Mar. 13, 23
Broadband Preamplifier (1GHz~18GHz)	SCHWARZBECK	BBV9718	305	May 12, 22
Pre-Amplifier (18GHz-40GHz)	EMCI	EMC 184045	980102	Jan. 10, 23
Power Sensor	Keysight	U2021XA	MY57320002	Feb.23.23
Power Sensor	Keysight	U2021XA	MY55060018	May 09, 22
Digital Multimeter	FLUKE	15B	A1220009DG	Aug. 07, 22
Humid & Temp Programmable Tester	Haida	HD-2257	110807201	Nov. 03, 22
Oscilloscope	Agilent	DSO9254A	MY51260160	Aug. 11, 22
Signal and Spectrum Analyzer	Rohde&Schwarz	FSV7	102331	May 09, 22
Spectrum Analyzer	Keysight	N9020A	MY55400499	Jan. 16, 23
MXG-B RF Vector Signal Generator	Keysight	N5182B	MY56200288	Sep. 14, 22
Wireless Connectivity Tester	Rohde&Schwarz	CMW270	100908	May 09, 22
Vector Signal Generator	Rohde&Schwarz	SMBV100A	257579	Sep. 04, 22
Attenuator	MINI	BW-S10W2+	S130129FGE2	N/A

NOTES:

1. The test was performed in 966 Chamber and RF Oven room. (Chenwu)
2. The calibration interval of the above test instruments is 12 months and the calibrations are traceable to CEPREI/CHINA, GRGT/CHINA and NIM/CHINA.
3. The horn antenna is used only for the measurement of emission frequency above 1GHz if tested.



For Receiver Blocking test and Adjacent channel selectivity test:

Equipment	Manufacturer	Model No.	Serial No.	Next Cal.
Wireless Connectivity Tester	Rohde&Schwarz	CMW270	100908	May. 09, 22
Signal Analyzer	Rohde&Schwarz	FSV7	102331	May 09, 22
Spectrum Analyzer	Keysight	N9020A	MY55400499	Jan. 16, 23
Signal Generator	Agilent	N5183A	MY50140980	Mar 23, 23
MXG-B RF Vector Signal Generator	Keysight	N5182B	MY56200288	Sep. 12, 22
Power Sensor	Keysight	U2021XA	MY55060016	N/A
Power Sensor	Keysight	U2021XA	MY55060018	May 09, 22
Vector Signal Generator	Rohde&Schwarz	SMBV100A	257579	Sep. 04, 22
Agile Signal Generator	Agilent	8645A	Agilent	N/A
Shield Box	TOJOIN	MS4345-C	SZA18A 3038	N/A
Attenuator	TOJOIN	CHB-8-90-1-B 50SMA	0803002	N/A
COM Power Splitter	TOJOIN	PS-TX-2B	020801	N/A
COM Power Splitter	TOJOIN	PS-TX-2B	020802	N/A
Test software	TonScend	JS1120-3-1	V2.6.88.0330	N/A

NOTES:

1. The test was performed in RF Oven room. (Chenwu)
2. The calibration interval of the above test instruments is 12 months and the calibrations are traceable to CEPREI/CHINA, GRGT/CHINA and NIM/CHINA.



1.2 MEASUREMENT UNCERTAINTY

Where relevant, the following measurement uncertainty levels have been estimated for tests performed on the EUT:

Parameter	Uncertainty
Radio frequency	$\pm 1.06 \times 10^{-8}$
RF power (conducted)	± 0.56 dB
Radiated emission of transmitter, valid up to 26.5GHz	± 4.84 dB
Radiated emission of transmitter, valid between 26.5GHz and 66GHz	± 4.96 dB
Radiated emission of receiver, valid up to 26.5GHz	± 4.84 dB
Radiated emission of receiver, valid between 26.5GHz and 66GHz	± 4.96 dB
Temperature	± 0.23 °C
Humidity	± 0.3 %
Voltages(DC)	± 0.1 %
Voltages(AC, <10kHz)	± 0.22 %

This uncertainty represents an expanded uncertainty expressed at approximately the 95% confidence level using a coverage factor of k=2.

1.3 MAXIMUM MEASUREMENT UNCERTAINTY

For the test methods, according to ETSI EN 300 440 standard, the measurement uncertainty figures shall be calculated in accordance with TR 100 028 [7] and shall correspond to an expansion factor (coverage factor) k = 1,96 or k = 2 (which provide confidence levels of respectively 95 % and 95,45 % in the case where the distributions characterizing the actual measurement uncertainties are normal (Gaussian)).

Parameter	Uncertainty
Radio frequency	$\pm 1 \times 10^{-7}$
RF power (conducted)	± 1.5 dB
Radiated emission of transmitter, valid up to 26.5GHz	± 6.0 dB
Radiated emission of transmitter, valid between 26.5GHz and 66GHz	± 8.0 dB
Radiated emission of receiver, valid up to 26.5GHz	± 6.0 dB
Radiated emission of receiver, valid between 26.5GHz and 66GHz	± 8.0 dB
Temperature	± 1 °C
Humidity	± 5.0 %
Voltages(DC)	± 1.0 %
Voltages(AC, <10kHz)	± 2.0 %



2 GENERAL INFORMATION

2.1 GENERAL DESCRIPTION OF EUT

PRODUCT	Wi-Fi Module		
MODEL NO.	P2		
ADDITIONAL MODEL	N/A		
NOMINAL VOLTAGE	DC 3.3V		
OPERATING VOLTAGE RANGE	V _{nom} =3.3V _{dc}	V _{min} = 2.7V _{dc}	V _{max} =3.63V _{dc}
OPERATING TEMPERATURE RANGE	-20 ~ + 70°C		
MODULATION TECHNOLOGY	OFDM		
MODULATION TYPE	256QAM, 64QAM, 16QAM, QPSK, BPSK for OFDM		
OPERATING FREQUENCY	5745MHz ~ 5825MHz		
EIRP POWER	13.47dBm (Measured Max.)		
ANTENNA TYPE	PCB antenna with 1.21dBi gain External PCB Antenna with 1.26dBi gain		
CABLE SUPPLIED	N/A		
RECEIVER CATEGORY	<input type="checkbox"/> Category 1	<input type="checkbox"/> Category 2	<input checked="" type="checkbox"/> Category 3

NOTES:

1. For a more detailed features description, please refer to the manufacturer's specifications or the user's manual.
2. For the test results, the EUT had been tested with all conditions, but only the worst case was shown in test report.
3. Please refer to the EUT photo document (Reference No.: 2207WDG0104) for detailed product photo.
4. The Wi-Fi Module uses two antennas, but couldn't transmit simultaneously, only the antenna type and gain are different. EIRP, PSD and radiation spurious emission have been evaluated for both antennas respectively. EIRP data and PSD data for both antennas are shown in the report, but only the worst antenna data (PCB antenna) is shown in the test report for the radiation spurious emission test.



5. The EUT provides completed transmitters and receivers, the EUT uses only one antenna at any time.

MODULATION MODE	TX FUNCTION
802.11a	1TX/1RX
802.11n (HT20) 802.11ac (VHT20)	1TX/1RX
802.11n (HT40) 802.11ac (VHT40)	1TX/1RX

* The modulation and bandwidth are similar for 802.11n mode for HT20 / HT40 and 802.11ac mode for VHT20 / VHT40, therefore investigated worst case for final test were chosen 802.11n (HT20/HT40) and record in the report.



2.2 DESCRIPTION OF TEST MODES

WLAN 5.745 ~ 5.825GHz

5 channels are provided for 802.11a, 802.11n (HT20), 802.11ac (VHT20):

CHANNEL	FREQUENCY	CHANNEL	FREQUENCY
149	5745MHz	161	5805MHz
153	5765MHz	165	5825MHz
157	5785MHz		

2 channels are provided for 802.11n (HT40), 802.11ac (VHT40):

CHANNEL	FREQUENCY	CHANNEL	FREQUENCY
151	5755MHz	159	5795MHz

2.3 GENERAL DESCRIPTION OF APPLIED STANDARDS

The EUT is a RF Product, according to the specifications of the manufacturers; it must comply with the requirements of the following standards:

EN 300 440 V2.2.1 (2018-07)

All test items have been performed and recorded as per the above standards.

2.4 DESCRIPTION OF SUPPORT UNITS

The EUT has been tested as an independent unit together with other necessary accessories or support units. The following support units or accessories were used to form a representative test configuration during the tests.

NO.	PRODUCT	BRAND	MODEL NO.	SERIAL NO.	FCC ID
1	Notebook	DELL	Inspiron 13-7378	GMSJZD2	N/A
2	PCB base support	N/A	N/A	N/A	N/A
3	DC Source	Keysight	E3642A	MY56146098	N/A

NO.	SIGNAL CABLE DESCRIPTION OF THE ABOVE SUPPORT UNITS
1	AC Line: Unshielded, Detachable 0.8m;DC Line: Unshielded, Non-detachable 1.8m USB Cable: Shielded, Detachable, 0.5m
2	N/A
3	AC Line: Unshielded, Detachable 1.0m



3 TEST TYPES AND RESULTS

TRANSMITTER PARAMETERS

3.1 EQUIVALENT ISOTROPIC RADIATED POWER

3.1.1 LIMITS OF EQUIVALENT ISOTROPIC RADIATED POWER

Condition	Limit (e.i.r.p)
Generic use(5725MHz to 5875MHz)	25 mW e.i.r.p.(14dBm)

For Extreme temperature ranges:

Category	Temperature range	The EUT Category
I (General)	-20°C to +55°C	-
II (Portable)	-10°C to +55°C	-
III (Equipment for normal indoor use)	5°C to +35°C	-
Declared by client	-20°C to +70°C	√

3.1.2 TEST PROCEDURES

Refer to chapter 4.2.2.3 of EN 300 440 V2.2.1 (2018-07).

3.1.3 DEVIATION FROM TEST STANDARD

No deviation.

3.1.4 TEST SETUP

1. Ran a test program to control EUT transmit at specific channel
2. A power meter was used to read the response of the power sensor.
3. Record the power level.
4. EIRP = antenna gain + power level of step 3.

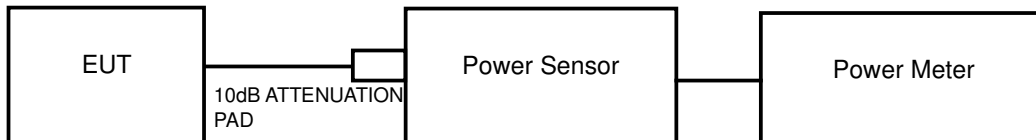



3.1.5 TEST RESULTS

802.11a

PCB Antenna

TEST CONDITION			EQUIVALENT ISOTROPIC RADIATED POWER (dBm)		
			(CH-149) 5745MHz	(CH-157) 5785MHz	(CH-165) 5825MHz
T _{nom} (°C)	25	V _{nom} (V)	13.05	11.75	11.57
T _{min} (°C)	-20	V _{min} (V)	13.45	11.95	11.97
		V _{max} (V)	13.47	11.96	11.95
T _{max} (°C)	+70	V _{min} (V)	12.84	11.60	11.06
		V _{max} (V)	12.84	11.58	11.09

802.11a

External PCB Antenna

TEST CONDITION			EQUIVALENT ISOTROPIC RADIATED POWER (dBm)		
			(CH-149) 5745MHz	(CH-157) 5785MHz	(CH-165) 5825MHz
T _{nom} (°C)	25	V _{nom} (V)	13.10	11.80	11.62
T _{min} (°C)	-20	V _{min} (V)	13.34	12.10	11.78
		V _{max} (V)	13.38	12.09	11.82
T _{max} (°C)	+70	V _{min} (V)	12.69	11.53	11.20
		V _{max} (V)	12.72	11.58	11.16



802.11n (20MHz)

PCB Antenna

TEST CONDITION			EQUIVALENT ISOTROPIC RADIATED POWER (dBm)		
			(CH-149) 5745MHz	(CH-157) 5785MHz	(CH-165) 5825MHz
T _{nom} (°C)	25	V _{nom} (v)	12.86	11.50	11.56
T _{min} (°C)	-20	V _{min} (v)	13.35	11.79	12.05
		V _{max} (v)	13.37	11.80	12.03
T _{max} (°C)	+70	V _{min} (v)	12.66	11.36	11.06
		V _{max} (v)	12.66	11.34	11.09

802.11n (20MHz)

External PCB Antenna

TEST CONDITION			EQUIVALENT ISOTROPIC RADIATED POWER (dBm)		
			(CH-149) 5745MHz	(CH-157) 5785MHz	(CH-165) 5825MHz
T _{nom} (°C)	25	V _{nom} (v)	12.91	11.55	11.61
T _{min} (°C)	-20	V _{min} (v)	13.29	11.89	11.76
		V _{max} (v)	13.32	11.90	11.80
T _{max} (°C)	+70	V _{min} (v)	12.38	11.05	11.39
		V _{max} (v)	12.41	11.10	11.36



802.11n (40MHz)

PCB Antenna

TEST CONDITION			EQUIVALENT ISOTROPIC RADIATED POWER (dBm)	
			(CH-151) 5755MHz	(CH-159) 5795MHz
T _{nom} (°C)	25	V _{nom} (V)	12.86	11.67
T _{min} (°C)	-20	V _{min} (V)	13.10	12.13
		V _{max} (V)	13.14	12.17
T _{max} (°C)	+70	V _{min} (V)	12.43	11.46
		V _{max} (V)	12.39	11.45

802.11n (40MHz)

External PCB Antenna

TEST CONDITION			EQUIVALENT ISOTROPIC RADIATED POWER (dBm)	
			(CH-151) 5755MHz	(CH-159) 5795MHz
T _{nom} (°C)	25	V _{nom} (V)	12.91	11.72
T _{min} (°C)	-20	V _{min} (V)	13.35	11.96
		V _{max} (V)	13.37	11.97
T _{max} (°C)	+70	V _{min} (V)	12.72	11.59
		V _{max} (V)	12.72	11.57



3.2 PERMITTED RANGE OF OPERATING FREQUENCIES

3.2.1 LIMITS OF PERMITTED RANGE OF OPERATING FREQUENCIES

The width of the power envelope is $f_H - f_L$ for a give operating frequency. In equipment that allow adjustment or selection of different frequencies, the power envelope take up different positions in the allowed band. The frequency range is determined by the lowest value of f_L and the highest value of f_H resulting from the adjustment of the equipment to the lowest and highest operating frequency.

CONDITION	LIMIT
Under all test conditions	$F_L > 5725.0\text{MHz}$ $F_H < 5875.0\text{MHz}$

3.2.2 TEST PROCEDURES

Refer to chapter 4.2.3.3 of EN 300 440 V2.2.1 (2018-07).

3.2.3 DEVIATION FROM TEST STANDARD

No deviation.

3.2.4 TEST SETUP

The EUT and probe antenna were placed into the temperature oven. The probe has to be connected with spectrum analyzer. The power source of the EUT has to be connected with the power supply for voltage change. The frequency has to be recorded for the right and left end above threshold of highest and lowest channel respectively.



3.2.5 TEST RESULTS

802.11a

TEST CONDITION			FREQUENCY (MHz)	
			LOWEST	HIGHEST
T _{nom} (°C)	25	V _{nom} (V)	5735.30	5834.55
T _{min} (°C)	-20	V _{min} (V)	5735.25	5834.65
		V _{max} (V)	5735.26	5834.61
T _{max} (°C)	+70	V _{min} (V)	5735.38	5834.48
		V _{max} (V)	5735.34	5834.51
Measured frequency (lowest and highest)			FL = 5733.19	FH = 5835.11

802.11n (20MHz)

TEST CONDITION			FREQUENCY (MHz)	
			LOWEST	HIGHEST
T _{nom} (°C)	25	V _{nom} (V)	5734.29	5835.71
T _{min} (°C)	-20	V _{min} (V)	5734.25	5835.81
		V _{max} (V)	5734.28	5835.83
T _{max} (°C)	+70	V _{min} (V)	5734.38	5835.64
		V _{max} (V)	5734.33	5835.63
Measured frequency (lowest and highest)			FL = 5734.25	FH = 5835.83



802.11n (40MHz)

TEST CONDITION			FREQUENCY (MHz)	
			LOWEST	HIGHEST
T _{nom} (°C)	25	V _{nom} (V)	5735.55	5814.45
T _{min} (°C)	-20	V _{min} (V)	5735.51	5814.56
		V _{max} (V)	5735.51	5814.54
T _{max} (°C)	+70	V _{min} (V)	5735.64	5814.39
		V _{max} (V)	5735.65	5814.40
Measured frequency (lowest and highest)			FL = 5735.51	FH = 5814.56



3.3 MEASUREMENT RADIATED SPURIOUS EMISSION

3.3.1 LIMITS OF MEASUREMENT RADIATED SPURIOUS EMISSION

Frequency Range	47MHz to 74MHz 87.5MHz to 108MHz 174MHz to 230MHz 470MHz to 862MHz	Other Frequencies Below 1GHz	>1GHz
Limit (Operating)	4nW (-54dBm)	250nW (-36dBm)	1µ W (-30dBm)
Limit (Standby)	2nW (-57dBm)	2nW (-57dBm)	20nW (-47dBm)

3.3.2 TEST PROCEDURES

Refer to chapter 4.2.4.3 of EN 300 440 V2.2.1 (2018-07).

3.3.3 DEVIATION FROM TEST STANDARD

No deviation.

3.3.4 TEST SETUP

1. For the actual test configuration, please refer to the related Item in this test report (Photographs of the Test Configuration).
2. The test setup has been constructed as the normal use condition. Controlling software (provided by manufacturer) has been activated to set the EUT on specific status.



3.3.5 TEST RESULTS

TX BELOW 1GHz WORST-CASE DATA: 802.11a

SPURIOUS EMISSION FREQUENCY RANGE	25MHz ~ 1GHz	OPERATING CHANNEL	149
--	--------------	--------------------------	-----

SPURIOUS EMISSION LEVEL				
Frequency (MHz)	Antenna Polarization	Level (dBm)	Limit (dBm)	Margin (dB)
60.94	H	-67.35	-54.00	-13.35
173.44	H	-69.40	-36.00	-33.40
242.19	H	-72.14	-36.00	-36.14
315.62	H	-64.18	-36.00	-28.18
537.50	H	-74.71	-54.00	-20.71
720.31	H	-70.49	-54.00	-16.49

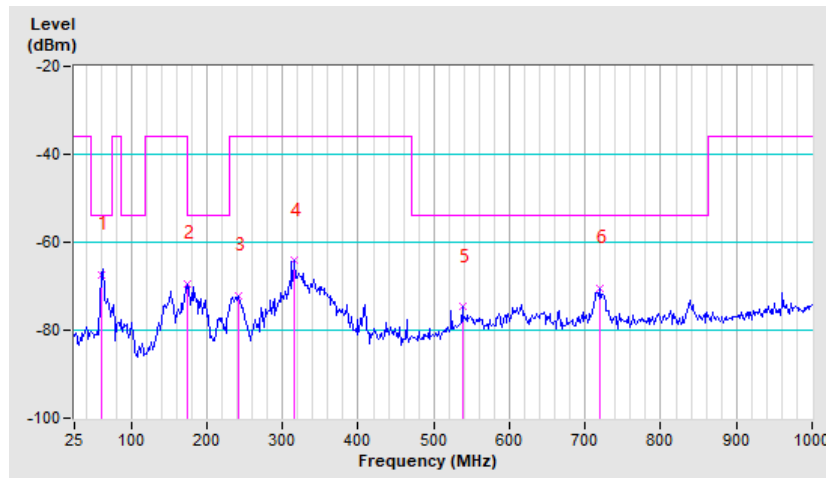



**BUREAU
VERITAS**

Test Report No.: RE2207WDG0104-3

SPURIOUS EMISSION FREQUENCY RANGE	25MHz ~ 1GHz	OPERATING CHANNEL	149
--	--------------	--------------------------	-----

SPURIOUS EMISSION LEVEL				
Frequency (MHz)	Antenna Polarization	Level (dBm)	Limit (dBm)	Margin (dB)
60.94	V	-58.74	-54.00	-4.74
140.62	V	-64.21	-36.00	-28.21
160.94	V	-65.85	-36.00	-29.85
307.81	V	-63.26	-36.00	-27.26
378.12	V	-63.16	-36.00	-27.16
712.50	V	-68.68	-54.00	-14.68

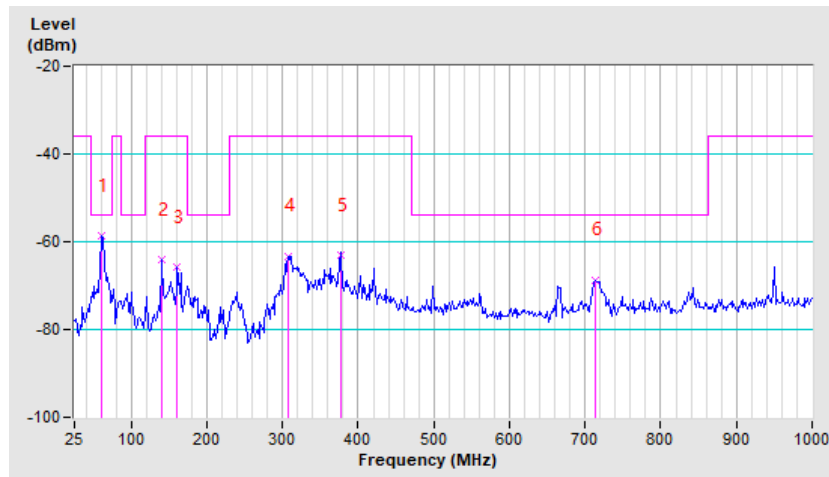



ABOVE 1GHz DATA: 802.11a

SPURIOUS EMISSION FREQUENCY RANGE	1GHz ~ 40GHz	OPERATING CHANNEL	149, 165
--	--------------	--------------------------	----------

SPURIOUS EMISSION LEVEL					
Channel	Frequency (MHz)	Antenna Polarization	Level (dBm)	Limit (dBm)	Margin (dB)
149	11490.00	H	-46.20	-30.00	-16.20
	11490.00	V	-47.21	-30.00	-17.21
	17235.00	H	-42.15	-30.00	-12.15
	17235.00	V	-43.62	-30.00	-13.62
165	11650.00	H	-45.26	-30.00	-15.26
	11650.00	V	-46.59	-30.00	-16.59
	17475.00	H	-41.57	-30.00	-11.57
	17475.00	V	-42.51	-30.00	-12.51

802.11n (20MHz)

SPURIOUS EMISSION FREQUENCY RANGE	1GHz ~ 40GHz	OPERATING CHANNEL	149, 165
--	--------------	--------------------------	----------

SPURIOUS EMISSION LEVEL					
Channel	Frequency (MHz)	Antenna Polarization	Level (dBm)	Limit (dBm)	Margin (dB)
149	11490.00	H	-46.51	-30.00	-16.51
	11490.00	V	-47.36	-30.00	-17.36
	17475.00	H	-41.96	-30.00	-11.96
	17475.00	V	-43.36	-30.00	-13.36
165	11650.00	H	-45.36	-30.00	-15.36
	11650.00	V	-46.51	-30.00	-16.51
	17475.00	H	-42.62	-30.00	-12.62
	17475.00	V	-43.32	-30.00	-13.32



802.11n (40MHz)

SPURIOUS EMISSION FREQUENCY RANGE	1GHz ~ 40GHz	OPERATING CHANNEL	151, 159
--	--------------	--------------------------	----------

SPURIOUS EMISSION LEVEL					
Channel	Frequency (MHz)	Antenna Polarization	Level (dBm)	Limit (dBm)	Margin (dB)
151	11510.00	H	-45.21	-30.00	-15.21
	11510.00	V	-46.51	-30.00	-16.51
	17265.00	H	-40.09	-30.00	-10.09
	17265.00	V	-43.52	-30.00	-13.52
159	11590.00	H	-43.51	-30.00	-13.51
	11590.00	V	-42.62	-30.00	-12.62
	17385.00	H	-39.65	-30.00	-9.65
	17385.00	V	-38.59	-30.00	-8.59



3.4 DUTY CYCLE (NOT APPLY)

3.4.1 LIMITS OF DUTY CYCLE

Frequency Band	Duty Cycle	Application
2400MHz to 2483.5MHz	No Restriction	Generic use
2400MHz to 2483.5MHz	No Restriction	Detection, movement and alert applications
(a) 2446MHz to 2454MHz	No Restriction	RFID
(b) 2446MHz to 2454MHz	15%	RFID
5725MHz to 5875MHz	No Restriction	Generic use
9200MHz to 9500MHz	No Restriction	Detection, movement and alert applications
9500MHz to 9975MHz	No Restriction	Detection, movement and alert applications
10.5GHz to 10.6GHz	No Restriction	Detection, movement and alert applications
13.4GHz to 14.0GHz	No Restriction	Detection, movement and alert applications
17.1GHz to 17.3GHz	DDA or equivalent techniques	GBSAR detecting and movement and alert applications
24.00GHz to 24.25GHz	No Restriction	Detection, movement and alert applications

3.4.2 TEST PROCEDURES

Refer to chapter 4.2.5.3 of EN 300 440 V2.2.1 (2018-07).

3.4.3 DEVIATION FROM TEST STANDARD

No deviation.

3.4.4 TEST SETUP

The test setup has been constructed as the normal use condition. Controlling software (provided by manufacturer) has been activated to set the EUT on specific status.

3.4.5 TEST RESULTS

This product does not apply.



RECEIVER PARAMETERS

3.5 LIMITES OF ADJACENT CHANNEL SELECTIVITY

The adjacent channel selectivity of the equipment under specified conditions shall not be less than $-30 \text{ dBm} + k$

Receiver category	Limit
1	$-30\text{dBm} + K$

The correction factor, k , is as follows:

$$k = -20\log f - 10\log BW$$

Where:

f is the frequency in GHz;

BW is the channel bandwidth in MHz.

The factor k is limited within the following:

$$-40 \text{ dB} < k < 0 \text{ dB}$$

3.5.1 TEST PROCEDURES

Refer to chapter 4.3.3.3 of EN 300 440 V2.2.1 (2018-07).



3.5.2 TEST SETUP

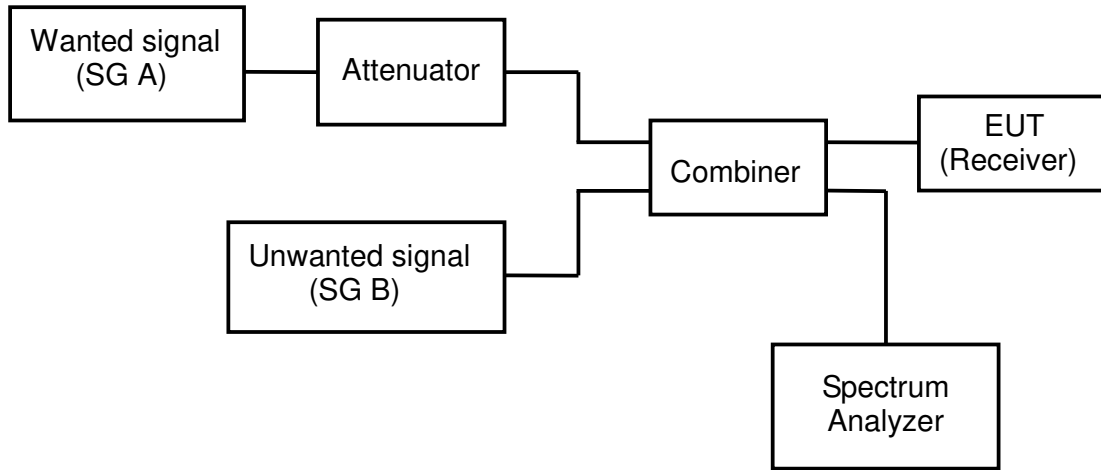

3.5.3 TEST RESULTS

This product does not apply.



3.6 BLOCKING OR DESENSITIZATION

3.6.1 LIMITES OF RECEIVER BLOCKING

The blocking level, shall not be less than the values given in table

Receiver category	Limit
1	-30dBm + K
2	-45dBm + K
3	-60dBm + K

The correction factor, k, is as follows:

$$k = -20\log f - 10\log BW$$

Where:

f is the frequency in GHz;

BW is the channel bandwidth in MHz.

The factor k is limited within the following:

$$-40 \text{ dB} < k < 0 \text{ dB}$$

3.6.2 TEST PROCEDURES

Refer to chapter 4.3.4.3 of EN 300 440 V2.2.1 (2018-07).

3.6.3 TEST SETUP

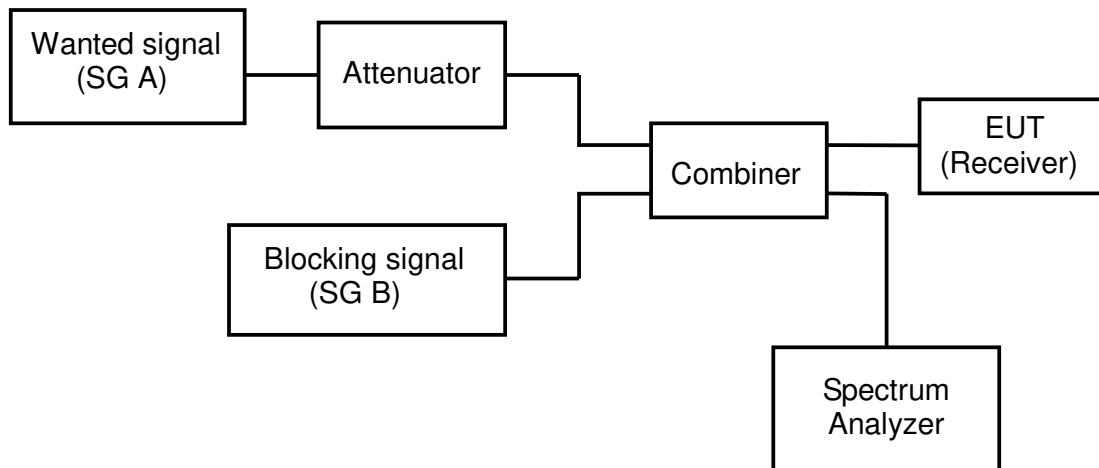



3.6.4 TEST RESULTS

Receiver Category 3 Equipment

For 802.11a

Blocking measure of the capability						
P _{min} : -75.17dBm						
The actual blocking signal power(Note)					<input checked="" type="checkbox"/> at the antenna connector <input type="checkbox"/> in front of the antenna	
Note: For the conducted measurements, the same level should be used at the antenna connector irrespective of antenna gain.						
Operation mode	Operation frequency (MHz)	Wanted signal power (dBm)	Offset of the bandwidth (times)	Blocking signal frequency (MHz)	Blocking signal Power (dBm)	Minimum Limit
Normal working	5775	-72.17	-10	5558.7485	-55.75	-87.67
			-20	5381.4695	-47.56	
			-50	4849.6325	-42.55	
			10	6011.83	-54.16	-87.81
			20	6189.832	-47.21	
			50	6723.838	-42.22	

Note:

Lower Channel: $K=-20\log f -10\log BW = -27.67$

Upper Channel: $K=-20\log f -10\log BW = -27.81$



OCCUPIED BANDWIDTH (FOR REFERENCE)

For 802.11a

CHANNEL	CHANNEL FREQUENCY (MHz)	OCCUPIED BANDWIDTH (MHz)
CH149	5745	17.7279
CH165	5825	17.8003

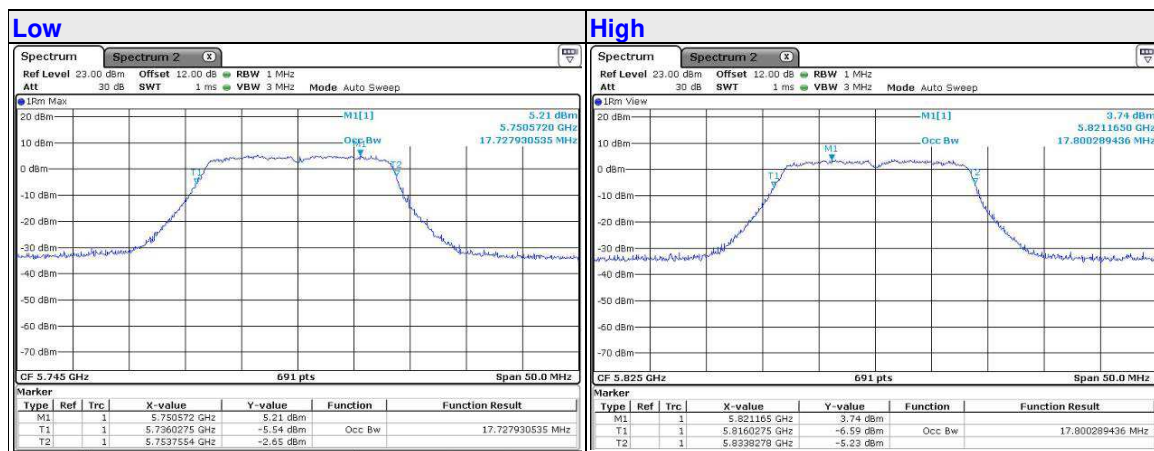



3.7 RECEIVER SPURIOUS EMISSIONS

3.7.1 LIMITS OF RECEIVER SPURIOUS EMISSIONS

Frequency range	Frequencies below 1GHz	Frequencies above 1GHz
Limit	2nW or -57dBm	20nW or -47dBm

3.7.2 TEST PROCEDURES

Refer to chapter 4.3.5.3 of EN 300 440 V2.2.1 (2018-07).

3.7.3 DEVIATION FROM TEST STANDARD

No deviation.

3.7.4 TEST SETUP

1. For the actual test configuration, please refer to the related Item in this test report (Photographs of the Test Configuration).
2. The test setup has been constructed as the normal use condition. Controlling software (provided by manufacturer) has been activated to set the EUT on specific status.



3.7.5 TEST RESULTS

RX BELOW 1GHz WORST-CASE DATA: 802.11a

SPURIOUS EMISSION FREQUENCY RANGE	25MHz ~ 1GHz	OPERATING CHANNEL	149
--	--------------	--------------------------	-----

SPURIOUS EMISSION LEVEL				
Frequency (MHz)	Antenna Polarization	Level (dBm)	Limit (dBm)	Margin (dB)
62.50	H	-66.03	-57.00	-9.03
175.00	H	-68.99	-57.00	-11.99
235.94	H	-71.99	-57.00	-14.99
317.19	H	-66.02	-57.00	-9.02
543.75	H	-74.71	-57.00	-17.71
717.19	H	-69.13	-57.00	-12.13

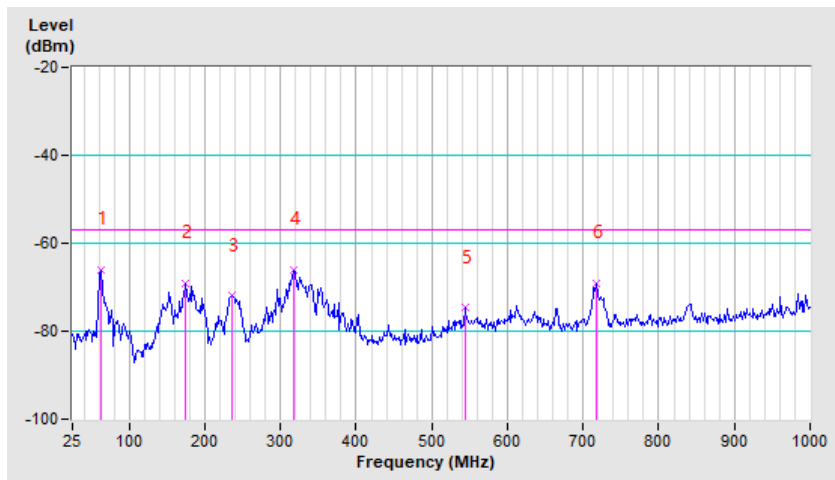



SPURIOUS EMISSION FREQUENCY RANGE	25MHz ~ 1GHz	OPERATING CHANNEL	149
--	--------------	--------------------------	-----

SPURIOUS EMISSION LEVEL				
Frequency (MHz)	Antenna Polarization	Level (dBm)	Limit (dBm)	Margin (dB)
60.94	V	-60.36	-57.00	-3.36
140.62	V	-67.17	-57.00	-10.17
165.62	V	-60.00	-57.00	-3.00
318.75	V	-65.39	-57.00	-8.39
382.81	V	-68.01	-57.00	-11.01
523.44	V	-73.27	-57.00	-16.27

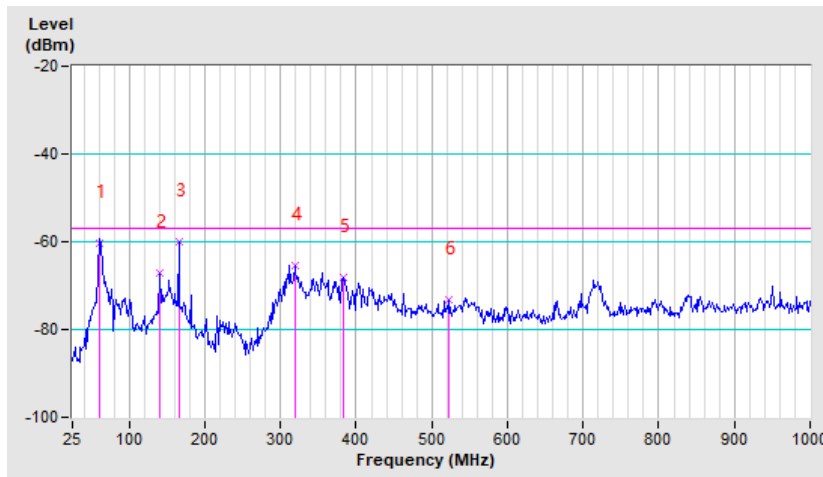



RX ABOVE 1GHz WORST-CASE DATA: 802.11a

SPURIOUS EMISSION FREQUENCY RANGE	1GHz ~ 40GHz	OPERATING CHANNEL	149, 165
--	--------------	--------------------------	----------

SPURIOUS EMISSION LEVEL					
Channel	Frequency (MHz)	Antenna Polarization	Level (dBm)	Limit (dBm)	Margin (dB)
149	11490.00	H	-51.96	-47.00	-4.96
	11490.00	V	-52.36	-47.00	-5.36
	17235.00	H	-50.84	-47.00	-3.84
	17235.00	V	-51.62	-47.00	-4.62
165	11650.00	H	-54.26	-47.00	-7.26
	11650.00	V	-55.10	-47.00	-8.10
	17475.00	H	-52.62	-47.00	-5.62
	17475.00	V	-53.10	-47.00	-6.10



4 PHOTOGRAPHS OF THE TEST CONFIGURATION

SPURIOUS EMISSION TEST BELOW 1GHz

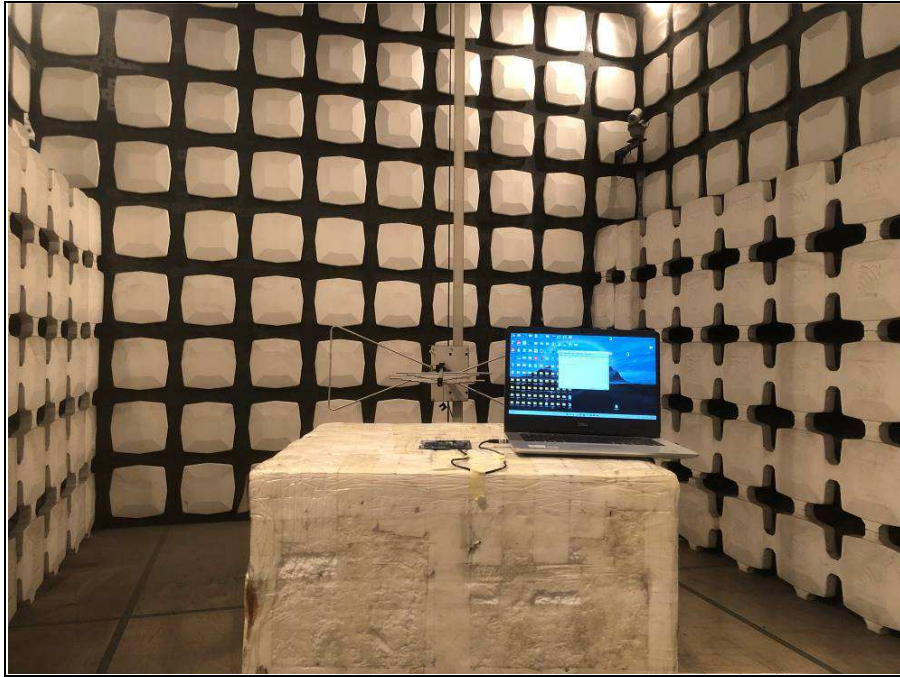

SPURIOUS EMISSION TEST ABOVE 1GHz

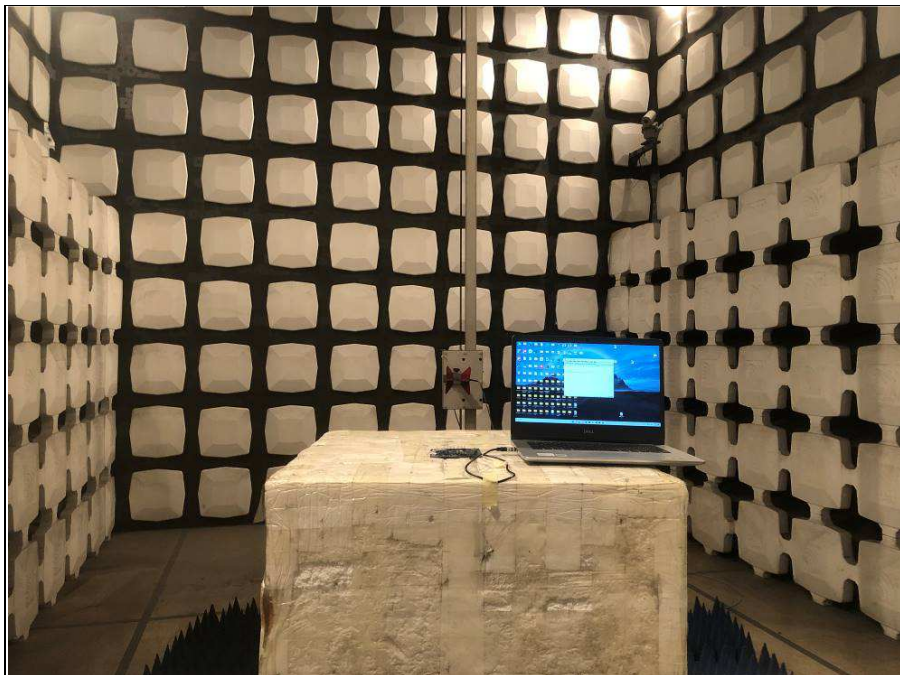



Test Report No.: RE2207WDG0104-3

5 APPENDIX A – MODIFICATIONS RECORDERS FOR ENGINEERING CHANGES TO THE EUT BY THE LAB

No any modifications were made to the EUT by the lab during the test.

---END---